



Thermo Scientific Cryofuge 8/16 Centrifuge and Heavy Duty Centrifuge

Instruction Manual

50149611-i • 03 / 2021

Table of Contents

Preface	vi
Items Supplied	vi
Intended Use for Cryofuge 8 / 16 and Cryofuge 16 Heavy Duty	vii
Intended User	vii
Associated Rotors and Components	vii
Precautions	viii
Set Up Conditions	viii
Preparation	ix
Hazardous Substances	ix
Operating	x
Maintenance	x
Symbols used on the Centrifuge	xi
Symbols used in the Manual	xii
Transport and Set Up	I-1
1. Location	I-1
2. Transporting	I-2
3. Setting Up	I-3
Setting Up	I-3
Level the Centrifuge	I-4
4. Mains Connection	I-5
5. Storage	I-5
6. Shipping	I-6
Thermo Scientific Centri-Touch User Interface	II-1
Status	II-2
Run Parameters	II-3
Control and Configuration	II-3
Lighthouse Mode	II-4
Operation	III-1
1. Switch on the Centrifuge	III-1

2. Open the Centrifuge Door	.III-1
3. Install a Rotor	.III-2
3. 1. Before Installation	III-2
3. 2. Rotor Installation	III-2
4. Maximum Loading	.III-8
Use of Tubes and Consumables	III-9
5. Close the Centrifuge Door	.III-9
6. Entering Parameters	.III-9
6. 1. Acceleration / Deceleration Profiles	III-9
6. 2. Preselect Speed / RCF-Value	III-9
6. 3. Runtime Preselection	III-10
6. 4. Preselect Temperature	III-10
6. 5. Pre-warm or Pre-cool the Centrifuge	III-10
7. Programs	III-11
8. Centrifugation	III-12
8. 1. Start	III-12
8. 2. Stop	III-12
8. 3. Using the Drain Box	III-13
9. Remove a Rotor	III-14
10. Switch off the Centrifuge	III-15
Maintenance and Care	IV-1
1. Cleaning Intervals	IV-1
2. Basics	IV-1
2. 1. Rotor and Components Inspection	IV-2
3. Cleaning	IV-3
3. 1. Touchscreen	IV-4
3. 2. Filter Mat	IV-5
4. Disinfection	IV-6
5. Decontamination	IV-6
6. Autoclaving	IV-7
7. Maintenance	IV-8
7. 1. Preventive Maintenance	IV-8
7. 2. Service	IV-8
8. Shipping and Disposal	IV-9

Troubleshooting	V-1
1. Mechanical Emergency Door Release	V-1
2. Ice Formation	V-2
3. Troubleshooting by Guide	V-3
4. Information for the Customer Service	V-4
Technical Specifications	A-1
1. Directives, Standards and Guidelines	A-2
2. Refrigerants	A-3
3. Mains Supply	A-3
4. Components	A-4
Rotors	B-1
Items Supplied for Rotors	B-1
HAEMAFlex 6 Rotor	B-2
HAEMAFlex 6 Rotor	B-3
HAEMAFlex 6 Rotor	B-4
HAEMAFlex 8 Rotor	B-5
HAEMAFlex 8 Rotor	B-6
HAEMAFlex 8 Rotor	B-7
HAEMAFlex 12 Rotor	B-8
HAEMAFlex 16 Rotor	B-9
Chemical Compatibility Chart	C-1

Table of Figures

Figure I-1: Centrifuge clearance, example with bar code scanner	I-2
Figure I-2: Position of the bubble in the water level.....	I-4
Figure I-3: Mains connection on the backside of the centrifuge	I-5
Figure III-1: Overview centrifuge and rotor, e.g. HAEMAFlex 12.....	III-2
Figure III-2: Align windshield knob and drive shaft.....	III-3
Figure III-3: Identify the circular marking, e.g. HAEMAFlex 8 and 12	III-3
Figure III-4: Rotor locking tool	III-4
Figure III-5: Put the rotor locking tool.....	III-4
Figure III-6: Tighten the rotor to the drive shaft	III-5
Figure III-7: Lubricate trunnion pins, e.g. HAEMAFlex 12	III-5
Figure III-8: Install buckets into rotor, e.g. HAEMAFlex 12	III-6
Figure III-9: Correctly assembled round bucket	III-6
Figure III-10: Correct Loading.....	III-7
Figure III-11: Incorrect Loading	III-7
Figure III-12: Insert windshield lid into holder	III-8
Figure III-13: Select program.....	III-11
Figure III-14: Drain box (75007730).....	III-13
Figure III-15: Installing the drain box (75007730).....	III-13
Figure III-16: Remove the plug	III-13
Figure III-17: Remove the rotor from the drive shaft.	III-14
Figure IV-1: Cleaning rotor bolts and bucket bearing surfaces	IV-4
Figure V-1: Marking on windshield lid.....	V-1
Figure V-2: Position of the mechanical emergency door release.....	V-2
Figure V-3: Example for an error message.....	V-3

Table of Tables

Table Preface–1: Items Supplied.....	vi
Table Preface–2: Signal Words and Colors	viii
Table Preface–3: Symbols used on the centrifuge.....	xi
Table Preface–4: Symbols used in the manual	xii
Table I–1: Overview of necessary tools for setting up.....	I–3
Table V–1: Error messages.....	V–3
Table A–1: Technical Data Thermo Scientific Cryofuge 8 / 16 and Cryofuge 16 Heavy Duty.....	A–1
Table A–2: Directives, Standards and Guidelines Cryofuge 8 / 16 and Cryofuge 16 Heavy Duty.....	A–2
Table A–3: Refrigerants used in the Cryofuge 8 / 16 and Cryofuge 16 Heavy Duty.....	A–3
Table A–4: Mains Supply	A–3
Table A–5: Components	A–5
Table B–1: Items supplied for rotors.....	B–1
Table B–2: HAEMAFlex 6 Rotor with Single Blood Bag Buckets (oval)	B–2
Table B–3: HAEMAFlex 6 Rotor with Single Blood Bag Buckets (round).....	B–3
Table B–4: HAEMAFlex 6 Rotor with Single Blood Bag Buckets with Filter Pack	B–4
Table B–5: HAEMAFlex 8 Rotor with Single Blood Bag Buckets (oval)	B–5
Table B–6: HAEMAFlex 8 Rotor with Single Blood Bag Buckets (round).....	B–6
Table B–7: HAEMAFlex 8 Rotor with Single Blood Bag Buckets with Filter Pack	B–7
Table B–8: HAEMAFlex 12 Rotor with Double Blood Bag Buckets	B–8
Table B–9: HAEMAFlex 12 Rotor with Double Blood Bag Buckets.....	B–9
Table C–1: Chemical Compatibility	C–11

Preface

Before starting to use the centrifuge, read through this instruction manual carefully and follow the instructions.

Failure to follow the instructions and safety information in this instruction manual will result in the expiration of the sellers Warranty.

Items Supplied

The centrifuges are supplied without a rotor. The items supplied with a rotor are listed in “Rotors” on page B–1.





Article No.	Item	Quantity
	Centrifuge	1
75007671	Thermo Scientific Cryofuge 8, 200, 208, 220, 230, 240 V \pm 10 %, 50 / 60 Hz, Single phase	
75007672	Thermo Scientific Cryofuge 8, 380, 400, 415 V \pm 10 %, 50 Hz, 3-phase	
75007673	Thermo Scientific Cryofuge 16, 200, 208, 220, 230, 240 V \pm 10 %, 50 / 60 Hz, Single phase	
75007674	Thermo Scientific Cryofuge 16, 380, 400, 415 V \pm 10 %, 50 Hz, 3-phase	
75007678	Thermo Scientific Cryofuge 16 Heavy Duty, 380, 400, 415 V \pm 10 %, 50 Hz, 3-phase	
	Power Supply Cable	1
	For single phase units with 200, 208, 220, 230, 240 V	
20190357	IEC60309 32A-6h 3-pin blue, 200–250 V 	
20190358	NEMA 6-30P 30A, 200–250 V 	
20190359	IEC60309 32A-6h 5-pin red (3P+N+PE), 220/380 V; 230/400 V; 240/415 V 	
20190364	NEMA L6-30P 30A, 200–205 V 	
	For 3-phase units with 380/400/415 V	
20190360	IEC60309 16A-6h 5 pin red (3P+N+PE), 220 / 380 V; 230 / 400 V; 240 / 415 V 	
20280119	Bubble Level	1
	Instruction Manual	1
	CD	1

Table Preface–1: Items Supplied

If any parts are missing, please contact the nearest Thermo Fisher Scientific representative.

Intended Use for Cryofuge 8 / 16 and Cryofuge 16 Heavy Duty

This centrifuge is intended for separation of blood into blood components using blood bags. The blood components are intended to be used for human blood transfusion.

Clinical facilities and institutions are responsible for the process of human blood transfusion.

This intended use is limited to the associated rotors and components. Based on the above this centrifuge is a medical device per European Directive 93/42/EEC.

Intended User

The centrifuge must be operated by trained personal only.

Trained personnel can be a clinical laboratory technologist, a medical laboratory technician or personal with similar education.

Associated Rotors and Components

The Thermo Scientific™ Cryofuge 8 centrifuge can be operated with the Thermo Scientific™ HAEMAFlex™ 6 and HAEMAFlex 8 rotor. The Thermo Scientific Cryofuge 16 and Thermo Scientific Cryofuge 16 Heavy Duty centrifuge can be operated with the Thermo Scientific HAEMAFlex 12 and HAEMAFlex 16 rotor. For more details on buckets and further components refer to ["Rotors"](#) on page B-1 and ["Components"](#) on page A-4.

Precautions



Signal Word and Color	Degree of Hazard
 WARNING	Indicates a hazardous situation that, if not avoided, could result in death or serious injury.
 CAUTION	Indicates a hazardous situation that, if not avoided, could result in minor or moderate injury.
NOTICE	Indicates information considered important, but not hazard-related.

Table Preface–2: Signal Words and Colors

WARNING

Observe the safety instructions. Not following these instructions can cause damage.

The centrifuge is to be used for its intended use only. Improper use can cause damages, contamination and injuries with fatal consequences.

The centrifuge must be operated by trained personnel only.

Thermo Fisher Scientific is not responsible for the process of human blood transfusion.

To ensure safe operation of this centrifuge regarding blood and blood components, you have to follow the regulations in your country.

 CAUTION	Due to air friction the temperature of rotor may raise significantly while the centrifuge is spinning. Refrigerated units have limitations in cooling capabilities. Displayed and set temperature can deviate from sample temperature. Sample temperature might exceed critical temperature of your application.
--	--

 WARNING	The magnets built into the rotors can have a negative effect on active implants, such as cardiac pacemakers. The magnets are mounted on the bottom of the rotor. Always keep a distance of 20 cm between the rotor and the active implant, as the product generates permanent magnetic fields. The magnetic field strength at a distance of 20 cm is less than 0.1 mT, so there should be no interference.
--	--

Set Up Conditions

WARNING

- Plug the centrifuge only into sockets which have been properly grounded.
- Turn off the centrifuge at the main switch. The mains plug must be freely accessible at all times.
Press the STOP key to shut down the centrifuge.
Pull out the power supply plug or disconnect the power supply in an emergency.
- As safety zone maintain a clear radius of at least 30 cm around the centrifuge.
Do not place any dangerous substances within this safety zone.
- Set up in a well-ventilated environment, on a horizontally leveled and rigid surface with adequate load-bearing capacity.

Preparation

WARNING

- It is the obligation of the operator to make sure, that the proper protective clothing is used. Mind the “Laboratory Biosafety Manual” of the World Health Organization (WHO) and the regulations in your country.
- Do not make any changes to the mechanical components of the centrifuge or rotor. Do not replace mechanical components.
- Do not touch the electronic components of the centrifuge. Do not make any changes to the electronic components. Do not replace electronic components.
- Use only a properly installed rotor. Follow the instructions in section “Install a Rotor” on page III–2.
- Do not use rotors, buckets or components which show any signs of removed protective coating, corrosion or cracks. Contact customer service for further advice or inspections.
- Use only with rotors which have been loaded properly.
- Never overload the rotor.
- Always balance the samples.
- Use only rotors and components for this centrifuge which have been approved by Thermo Fisher Scientific. Exceptions to this rule are commercially available glass or plastic centrifuge lab ware, provided they have been designed to fit the rotor or the adapter cavities and are approved for the speed or the RCF value of the rotor.
- Make sure the rotor is locked properly into place before operating the centrifuge.
- Implement measures which ensure that no one can approach the centrifuge for longer than absolutely necessary while it is running.

Hazardous Substances

WARNING

- Especially when working with corrosive samples (salt solutions, acids, bases), the Components and the centrifuge chamber have to be cleaned thoroughly.
- Do not centrifuge explosive or flammable materials or substances.
- The centrifuge is neither inert nor protected against explosion. Never use the centrifuge in an explosion-prone environment.
- Do not centrifuge toxic or radioactive materials or any pathogenic micro-organisms without suitable safety precautions.

If centrifuging any hazardous materials mind the “Laboratory Biosafety Manual” of the World Health Organization (WHO) and any local regulations. When centrifuging microbiological samples from the Risk Group II (according to the “Laboratory Biosafety Manual” of the World Health Organization (WHO)), aerosol-tight biological seals have to be used. Look on the Internet page of the World Health Organization (www.who.int) for the “Laboratory Biosafety Manual”. For materials in a higher risk group, extra safety measures have to be taken.

- If toxins or pathogenic substances have contaminated the centrifuge or its parts, appropriate disinfection measures have to be taken (“Disinfection” on page IV–6).
- Extreme care should be taken with highly corrosive substances which can cause damage and impair the mechanical stability of the rotor. These should only be centrifuged in fully sealed tubes.
- If a hazardous situation occurs, turn off the power supply to the centrifuge and leave the area immediately.

Operating

WARNING

- Never use the centrifuge, if parts of its casing is damaged or missing.
- Never start the centrifuge when the centrifuge door is open.
- Do not move the centrifuge while it is running.
- Do not lean on the centrifuge.
- Do not place anything on top of the centrifuge during a run.
- Never open the centrifuge door until the rotor has come to a complete stop and this has been confirmed on the touchscreen.
- The emergency door release may be used in emergencies only to recover the samples from the centrifuge, e.g. during a power failure ([“Mechanical Emergency Door Release” on page V-1](#)).
- Do not open the centrifuge, while it is running.

In any case of severe mechanical failure, such as rotor or bucket crash, the centrifuge is not aerosol-tight.

In case of rotor failure the centrifuge can be damaged. Leave the room. Inform customer service.

Maintenance

WARNING

The centrifuge housing is not to be opened by the operator.

Symbols used on the Centrifuge



This symbol refers to general hazards. Observe the information contained in the instruction manual to keep yourself and your environment safe.

CAUTION means that material damage could occur.

WARNING means that injuries or material damage or contamination could occur.



This symbol refers to biological hazards.

Observe the information contained in the instruction manual to keep yourself and your environment safe.



This symbol refers to hazards from sharp items.

Observe the information contained in the instruction manual to keep yourself and your environment safe.



This symbol refers to hazards from closing mechanical parts.

Observe the information contained in the instruction manual to keep yourself and your environment safe.



This symbol refers to information on hazards, described within the manual.

Observe the information contained in the instruction manual to keep yourself and your environment safe.



This symbol on rotors and components refers to information on hazards, described within the manual.

Observe the information contained in the instruction manual to keep yourself and your environment safe.



This symbol demands to disconnect mains before transporting or servicing the centrifuge.



This symbol shows the direction of rotation.

Table Preface–3: Symbols used on the centrifuge

Symbols used in the Manual



This symbol refers to general hazards. Observe the information contained in the instruction manual to keep yourself and your environment safe.

CAUTION means that material damage could occur.

WARNING means that injuries or material damage or contamination could occur.



This symbol refers to biological hazards.

Observe the information contained in the instruction manual to keep yourself and your environment safe.

Table Preface–4: Symbols used in the manual

Transport and Set Up



CAUTION

Make sure that the centrifuge and the packaging is not damaged. Speak to the shipping company and Thermo Fisher Scientific immediately, if damage is found.

1. Location



WARNING

Risk of impact.

The centrifuge can crush into objects and persons in a radius of 30 cm when spinning.

Keep a safety zone of 30 cm around the centrifuge for safe operation.

Make sure that no one is in the safety zone while the centrifuge spins.



CAUTION

UV rays decrease the stability of plastics.

Do not expose the centrifuge, rotors and plastic components to direct sunlight.

Operate the centrifuge only inside a room.

The set-up location must fulfill these requirements:

- Keep a safety zone of minimum 30 cm ([Figure I-1 on page I-2](#), green area) around the centrifuge. Persons and hazardous substances must be kept out of this safety zone while centrifuging.
- The supporting structure must:
 - » be stable and free of resonance,
 - » be applicable for horizontal setup of the centrifuge,
 - » hold the weight of the centrifuge.
- Do not expose the centrifuge to heat and strong sunlight.
- The set-up location must be well-ventilated at all times.

THE ACTIVITIES DESCRIBED IN THIS CHAPTER ARE FOR SERVICE TECHNICIANS.

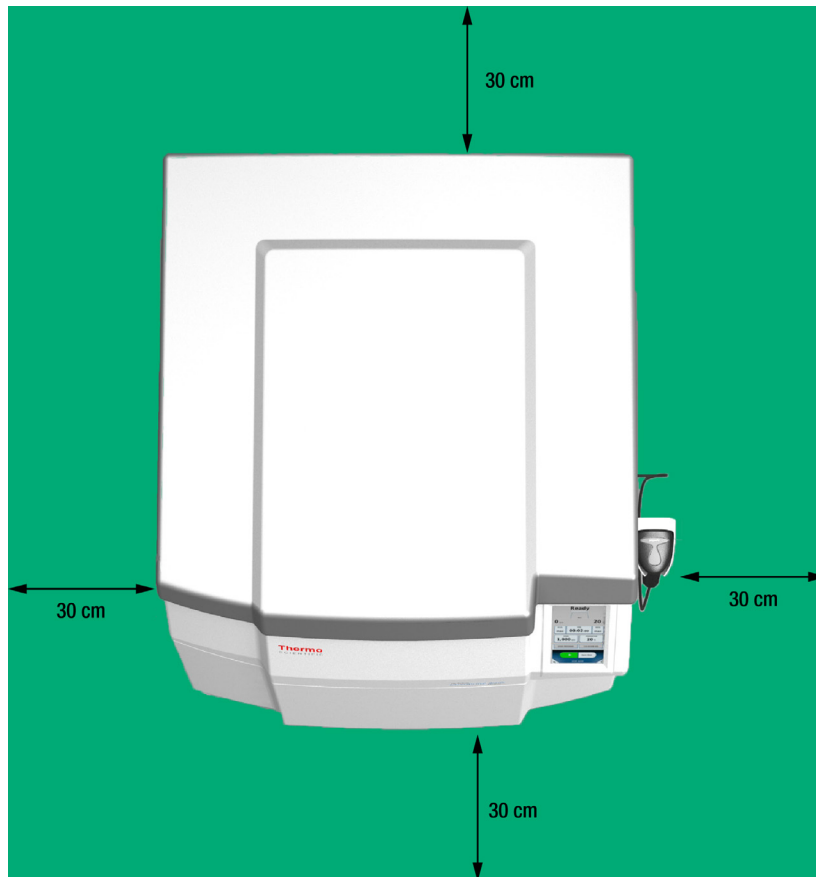

Figure I-1: Centrifuge clearance, example with bar code scanner

2. Transporting



WARNING

Never stand before a moving centrifuge to stop it.

If the centrifuge is moved on an uneven surface, it can get faster due to its own weight.

An impact of the centrifuge can lead to serious injuries.



CAUTION

Always remove the rotor before you transport the centrifuge.

If you do not remove the rotor you can damage the centrifuge drive or drive shaft.

NOTICE

Dispose the centrifuge packaging.

NOTICE

Assign a shipping company for the transport.

Inform the customer service about the transport.

- Use a forklift to lift a centrifuge that is fixed on a palette.
- Impact can damage the centrifuge.
- Send the centrifuge upright and if possible in packaging.

THE ACTIVITIES DESCRIBED IN THIS CHAPTER ARE FOR SERVICE TECHNICIANS.

THE ACTIVITIES DESCRIBED IN THIS CHAPTER ARE FOR SERVICE TECHNICIANS.

3. Setting Up



CAUTION

Do not push at the touchscreen.
Due to the weight of the centrifuge it must be controlled by two or more people when rolling of the pallet. Do not stand in front of the centrifuge when rolling it down the ramp.
The centrifuge has four steering casters that must be parallel, so that the centrifuge can be moved from the pallet.

Make sure that the items supplied are complete (“Items Supplied” on page vi).

If the items supplied are not complete, please speak to Thermo Fisher Scientific.

Necessary Tools













Graphic	Item	Quantity
	Wrench (30 mm)	2
	Socket wrench with nut (19 mm)	1
	Screwdriver (torque T30)	1
	Screwdriver (torque T20)	1
	Hexagon key (hexagon 4 mm)	1
	Hexagon key (hexagon 5 mm)	1
	Cutter	1

Table I-1: Overview of necessary tools for setting up

Setting Up

1. Remove the wooden plank on the backside of the pallet. The backside of the pallet is the side with the bevels.
-  2. Screw both rails on the bevels. Make sure that you position them not at the edge of the pallet.
3. Remove the metal pipes
 -  a. Remove the 4 screws from the downside of the pallet.
 -  b. Lift the centrifuge by turning down the 4 centrifuge feet until the metal pipes can be removed.
 -  c. Remove the metal pipes.
4. Lower the centrifuge by lifting the 4 centrifuge feet.
Make sure that the 4 centrifuge feet are entirely turned up to the bottom of the centrifuge.
5. Move the centrifuge from the pallet.
6. Move the centrifuge to the location, where you want to operate it.
-  7. Turn down the 4 centrifuge feet until all 4 casters are not in contact with the ground. All 4 centrifuge feet need to have firm contact to the ground (“Level the Centrifuge” on page I-4). The maximum height for setting up is 9.5 cm (3.7 inch) measured from the ground to the bottom of the centrifuge.
-  8. To fasten the 4 centrifuge feet you have to fasten their two lock nuts. The lower lock nut has to be fastened gently down against the foot. The upper lock nut has to be fastened up against the centrifuge bottom.

THE ACTIVITIES DESCRIBED IN THIS CHAPTER ARE FOR SERVICE TECHNICIANS.

THE ACTIVITIES DESCRIBED IN THIS CHAPTER ARE FOR SERVICE TECHNICIANS.

Level the Centrifuge



CAUTION

If you do not level the centrifuge, the centrifuge can crash because of imbalance.
If you move the centrifuge, you must level it again.
Do not move the centrifuge with a rotor attached to the drive shaft because damage can occur to the drive.
Do not put anything below the centrifuge feet to level the centrifuge.

Level the centrifuge as follows:

1. Put the bubble level on the top of the drive shaft in the centrifugation chamber.
2. Adjust the centrifuge feet until the bubble in the level is fully in the circle mark.
3. Turn the drive shaft with the bubble level around a full turn.

If 50% of the bubble stays in the circle mark, the centrifuge is leveled. If more than 50% of the bubble is out of the circle mark, the centrifuge must be leveled again.

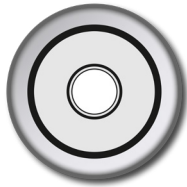

Excellent

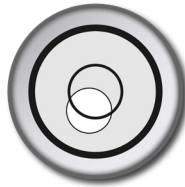

Acceptable

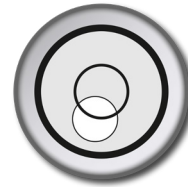

Unacceptable

Figure I-2: Position of the bubble in the water level



4. To fasten the 4 centrifuge feet you have to fasten their two lock nuts. The lower lock nut has to be fastened gently down against the foot. The upper lock nut has to be fastened up against the centrifuge bottom.

THE ACTIVITIES DESCRIBED IN THIS CHAPTER ARE FOR SERVICE TECHNICIANS.

THE ACTIVITIES DESCRIBED IN THIS CHAPTER ARE FOR SERVICE TECHNICIANS.

4. Mains Connection

NOTICE

Connect the centrifuge into grounded electrical sockets only.

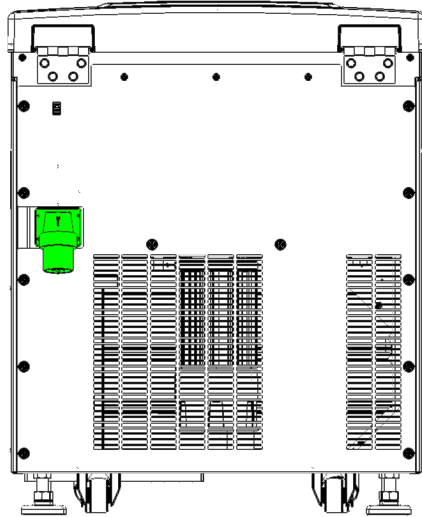

Figure I-3: Mains connection on the backside of the centrifuge

1. Turn off the power supply switch located on the right side (pull the switch handle towards the front of the centrifuge).
2. Make sure that the cable specification agrees with the safety standards of your country.
3. Make sure that the voltage and frequency are the same as the figures on the rating plate.

5. Storage



WARNING

When you remove the centrifuge and components from use, clean and if necessary, disinfect or decontaminate the full system. If you are not sure speak to the Thermo Fisher Scientific customer service.

- Before storing the centrifuge and the components it must be clean and if necessary disinfected and decontaminated. Centrifuge, rotors, buckets and components have to be fully dry before storage.
- Keep the centrifuge in a clean, dust-free location.
- Keep the centrifuge on its rubber feet and not on its casters.
- Do not store the centrifuge in direct sunlight.

THE ACTIVITIES DESCRIBED IN THIS CHAPTER ARE FOR SERVICE TECHNICIANS.

THE ACTIVITIES DESCRIBED IN THIS CHAPTER ARE FOR SERVICE TECHNICIANS.

6. Shipping



WARNING

Before shipping the centrifuge and components you must clean and if necessary, disinfect or decontaminate the full system. If you are not sure speak to the Thermo Fisher Scientific customer service.

Before shipping the centrifuge:

- The centrifuge must be clean and decontaminated.
- You must confirm the decontamination with a decontamination certificate.

THE ACTIVITIES DESCRIBED IN THIS CHAPTER ARE FOR SERVICE TECHNICIANS.



Thermo Scientific Centri-Touch User Interface

①	Actual status information
②	Set values
③	Settings and navigation

Status

The upper part of the touchscreen displays the centrifuge status.

The remaining time is indicated while centrifugation is in progress. The progress bar shows the actual phase of the centrifugation.

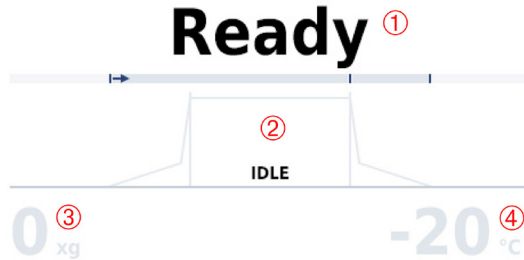

- ① **Status:** In the Time mode, the remaining time for the centrifugation process is shown here. In the Hold mode, the elapsed time is displayed.
- ② **Progress:** The curve diagram is divided into the sections acceleration, centrifugation and deceleration.
- ③ **Speed:** The current speed of the rotor is shown here.
- ④ **Temperature:** The temperature in the centrifugation chamber is shown here.

Status that can be displayed

Ready	Centrifugation can be started.
Door open	Centrifuge door is open.
Door moving	Door is automatically closing or opening.
Error	An error has occurred.
Canceled	Centrifugation has been stopped manually.
Complete	Centrifugation has been successfully completed.
Pretempering completed	Pretempering has been successfully completed.
No rotor	No rotor is identified in the centrifuge.

Run Parameters

The set points for centrifugation can be set in the parameterization window. Clicking one of these buttons will open a new window in which you can input the appropriate set point value.

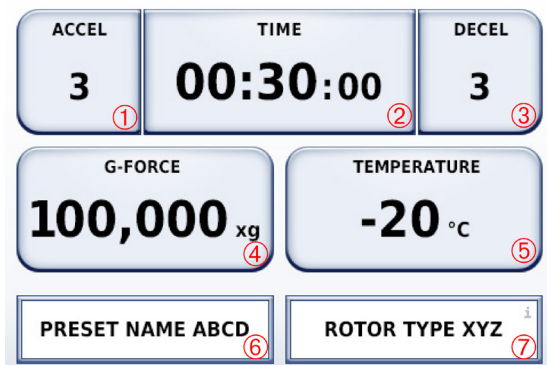

- ① **Acceleration:** Select an acceleration profile (Level 1-10).
- ② **Time:** Select the duration for centrifugation and the time mode.
- ③ **Deceleration:** Select the deceleration profile (1-10).
- ④ **Speed:** Set the speed as rpm or RCF.
- ⑤ **Temperature:** Set the temperature (in °C) for the centrifugation chamber.
- ⑥ **Program:** Select a program for centrifugation. The previously selected program will always be displayed initially. You can change the parameters once you have selected a program. Changing a parameter will cancel the program.
- ⑦ **Rotor:** The rotor currently in use is displayed.

Control and Configuration

In this section you can start and halt centrifugation. You can also define settings, such as for the centrifugation programs. If you are not sure of the use of a button you can use the tooltip mode, which provides information about all of the operator control elements.



- ① **Start centrifugation:** Centrifugation can be started using the current set values.
- ② **Open Door / Stop:** When centrifugation starts, this button switches to **Stop** .
- ③ **Configuration:** The configuration menu is displayed when this button is clicked. This button is not active while centrifugation is in progress.
- ④ **Operator:** In certain modes, touching the operator name opens a window for selecting other operators.
- ⑤ **Tooltip Mode:** This button is used to activate the tooltip mode. All functional elements are deactivated with this mode. When an element is selected in the tooltip mode a field is displayed with information about that particular element. If you press the tooltip button again, this mode is canceled.

Lighthouse Mode

If no entry is made via the main screen in 30 seconds, the unit changes to lighthouse mode. In this mode, the status, current values and progress display are displayed larger.

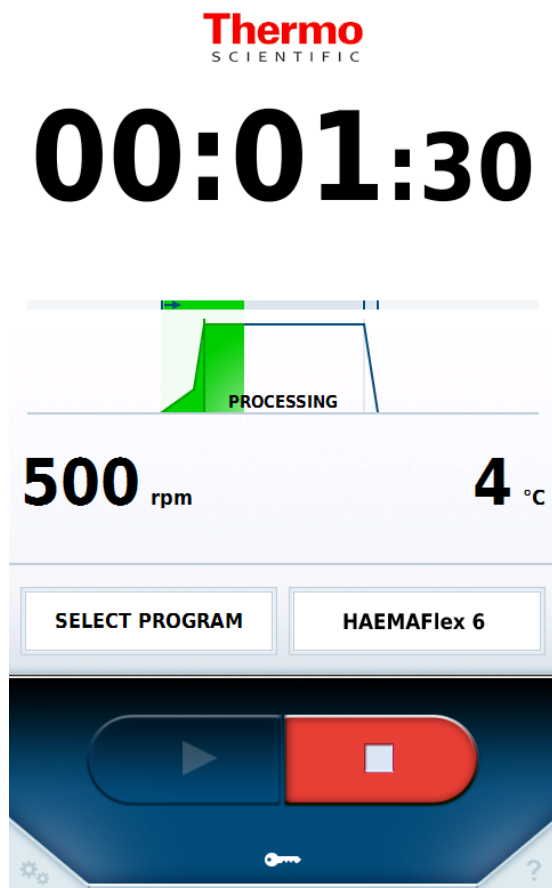

The set value entry fields disappear and the progress display occupies their space. The time display is enlarged, so that the centrifugation status can be seen clearly from a greater distance. It is still possible to stop the centrifuge. Pressing on any area of the screen causes it to exit from lighthouse mode.



Operation

For detailed instructions and information refer to the separate manual for the Thermo Scientific™ Centri-Touch™ User Interface.

1. Switch on the Centrifuge

Push the switch at the right side.

The centrifuge checks its software. The touchscreen shows the Thermo Scientific logo while booting.

When ready the touchscreen shows the current status of the centrifuge.

2. Open the Centrifuge Door

Press the **Open** button on the touchscreen ([“Control and Configuration” on page II-3](#)). The centrifuge door will be opened automatically with the Thermo Scientific™ Auto-Door™ function.

The centrifuge door can only be opened when the centrifuge is switched on.



CAUTION

Do not use the mechanical emergency door release as regular procedure to open the centrifuge . Use the mechanical emergency door release, only if a malfunction or power failure occurs and only when you have made sure that the rotor stopped spinning. ([“Mechanical Emergency Door Release” on page V-1](#))

3. Install a Rotor



WARNING

If you have not installed the rotor correctly, do not operate it.
Make sure that the rotor is not damaged. Do not use damaged rotors.
Make sure that the centrifugation chamber is free from objects.

NOTICE

Two persons are necessary for this procedure because of the weight of a rotor.

3.1. Before Installation

Make sure that all rotor parts are clean, dry and have no nicks and scratches. Always use a rotor body, a windshield bowl and a windshield lid that have the same article number.

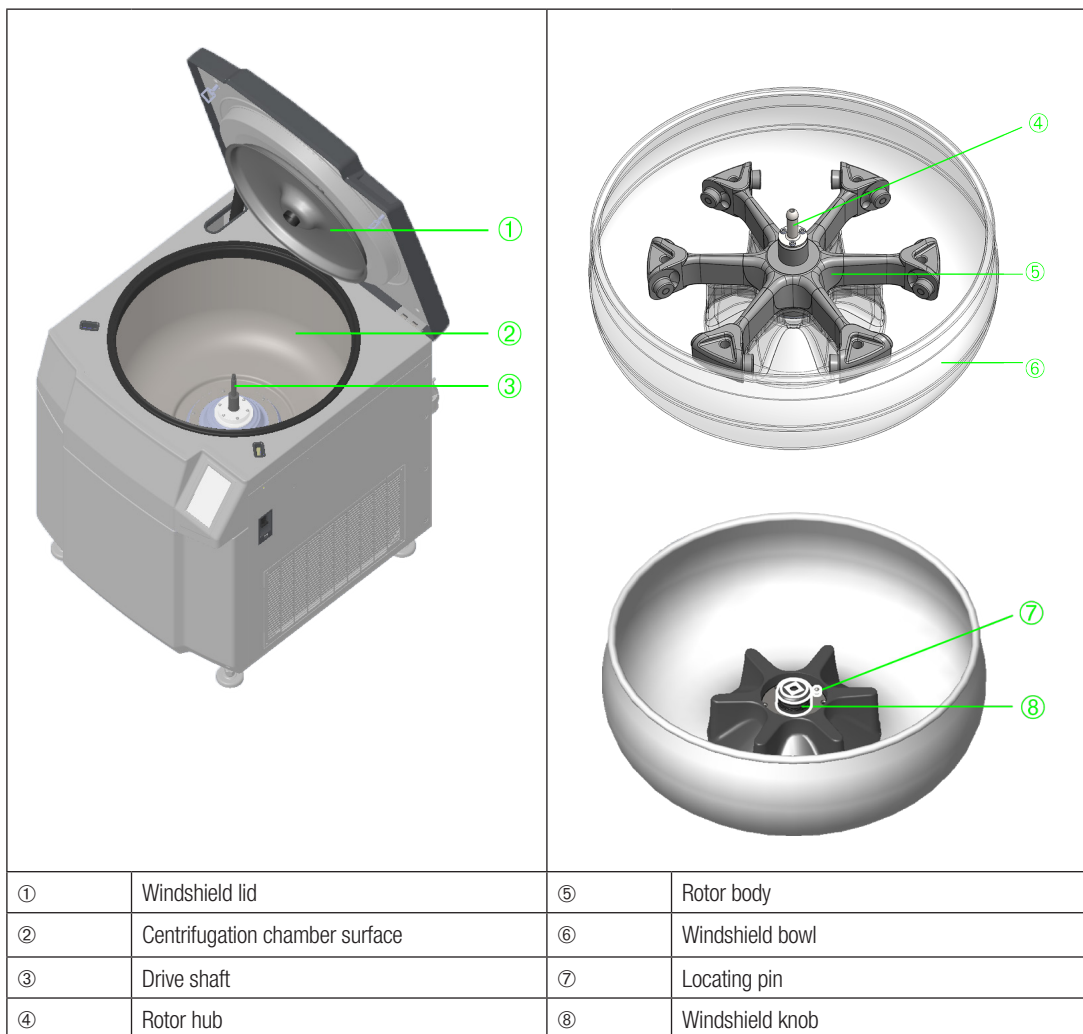

Figure III-1: Overview centrifuge and rotor, e.g. HAEMAFlex 12

3.2. Rotor Installation



CAUTION

Make sure the rotor is locked properly into place before operating the centrifuge.
Make sure once a week that the rotor locking pin is locked properly. Use the rotor locking tool (20360104) clockwise to check, if the rotor locking pin is tightened to the firm stop.



CAUTION

If you have not installed the rotor correctly, do not operate it.
Make sure that the rotor is not damaged. Do not use damaged rotors.
Make sure that the centrifugation chamber is free from objects.

1. Open the lid of the centrifuge.

If necessary remove dust and foreign objects from the chamber.

Wipe the drive shaft and the rotor hub from the bottom side of the rotor with a clean cloth. Apply one drop of grease (75003786) to the drive shaft.

2. Hold the windshield bowl at the windshield knob with one hand and at the rim with the other hand.

Put the windshield bowl carefully on the drive shaft.

For some windshield bowls it may be easier to handle them with 2 people.

3. Align the square symbol on the windshield knob to the square end on the drive shaft.

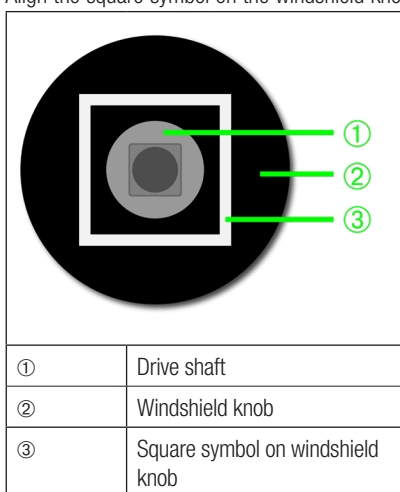

Figure III-2: Align windshield knob and drive shaft

4. Identify the circular marking on the rotor body.

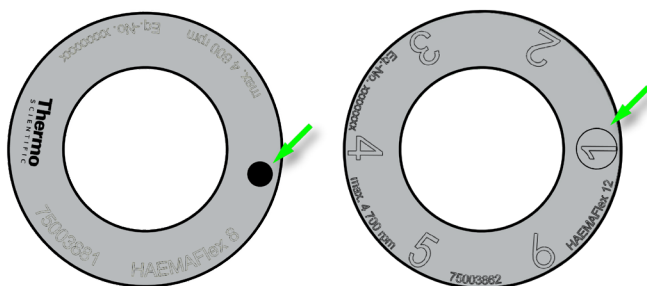

Figure III-3: Identify the circular marking, e.g. HAEMAFlex 8 and 12

The hole for the locating pin of the windshield bowl is on the bottom side of the rotor body below the circular marking. Hold the rotor body over the drive shaft and align the circular marking to the locating pin on the windshield bowl. Put the rotor body carefully on the drive shaft. Turn the rotor body against the windshield bowl until the locating pin engages into the rotor body.



CAUTION

The centrifuge drive can be damaged, if the rotor body falls on it.

If the rotor body is not engaged correctly it is not possible to turn the rotor locking pin into the drive shaft. Repeat step 3 and 4 until the rotor body is in position.

5. To prevent possible damage to rotor or centrifuge, clean the threads of the drive shaft.

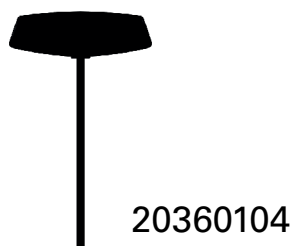

Figure III-4: Rotor locking tool

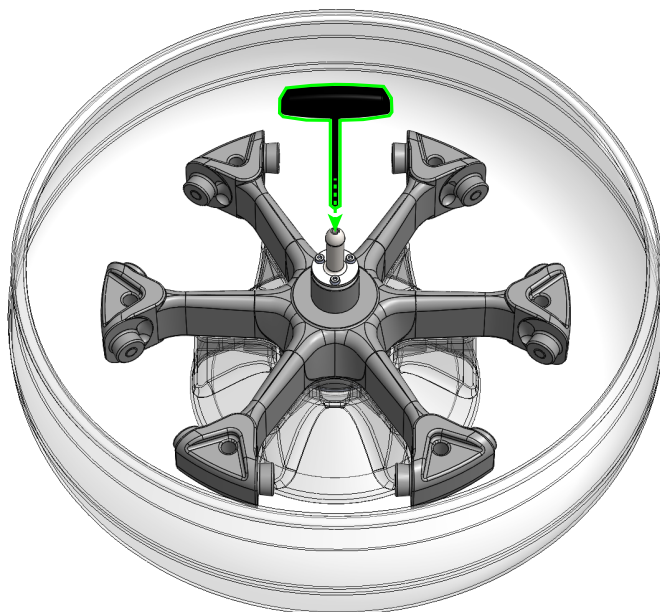

Figure III-5: Put the rotor locking tool

Put the rotor locking tool (20360104) into the opening of the guiding pin into the rotor locking screw.

Use the rotor locking tool (20360104) clockwise to tighten the rotor with the rotor locking screw to the drive shaft.



CAUTION

Make sure the rotor is locked properly into place before operating the centrifuge. Make sure once a week that the hidden rotor locking screw is locked properly. Use the rotor locking tool (20360104) clockwise to check if the rotor locking screw is tightened to the firm stop.



CAUTION

Use only the supplied rotor locking tool (20360104) to avoid an overload on the fixation parts. Over-tightening of the rotor locking screw can lead to an improper installation of the rotor possibly causing severe damage to the rotor and the centrifuge.

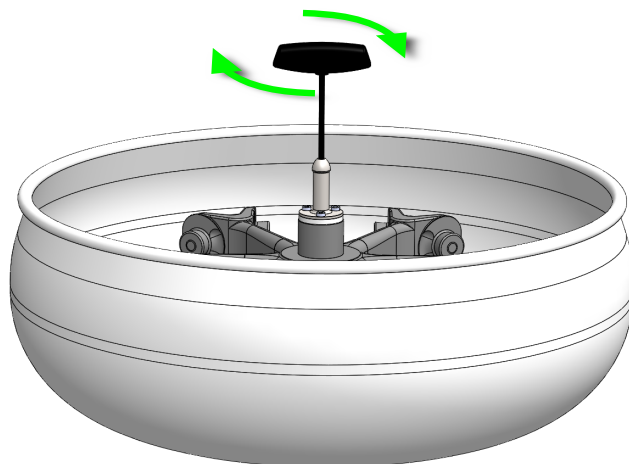

Figure III-6: Tighten the rotor to the drive shaft

6. Clean and lubricate the rotor trunnion bolts and the two bolt seats on the sides of each bucket ("Cleaning" on page IV-3).

To prevent possible damage to rotor or centrifuge, apply grease (75003786) to the rotor trunnion bolts. This must be done each time you install buckets. One small drop of grease is necessary for each rotor trunnion bolt. Example: each highlighted rotor trunnion bolt in the picture needs to be greased.

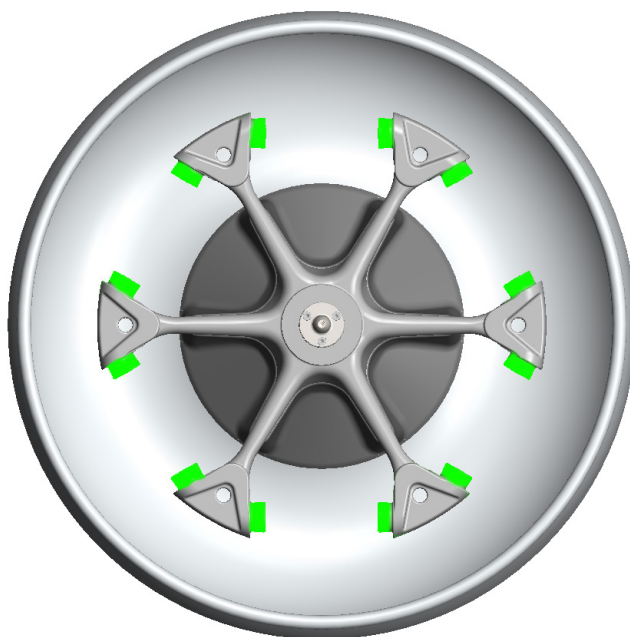

Figure III-7: Lubricate trunnion pins, e.g. HAEMAFlex 12

7. Install an empty bucket in each position. Install buckets with the same weight class on opposing positions. Make sure that each bucket swings out correctly. They must swing freely on their rotor trunnion bolts.



CAUTION

Always use a full complement of buckets, even if some stay empty.



Figure III-8: Install buckets into rotor, e.g. HAEMAFlex 12

When assembling round buckets insert the O-ring below the thread in the bucket. Do not insert it to the bucket lid.

The bucket is assembled correctly, if the handles of the bucket lid are not aligned to the bolt seats of the bucket. If they are aligned to the bolt seats, the bucket is not closed correctly.

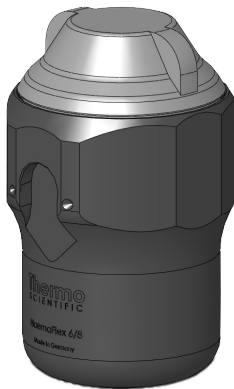

Figure III-9: Correctly assembled round bucket

8. Load the buckets evenly. Balance opposite loads.



CAUTION

Incorrect loading can lead to damages. Always load the rotor symmetrically to avoid imbalance, bumpy spinning and possible damages. A full complement of buckets needs to be installed before operating the rotor.

Correct Loading ✓

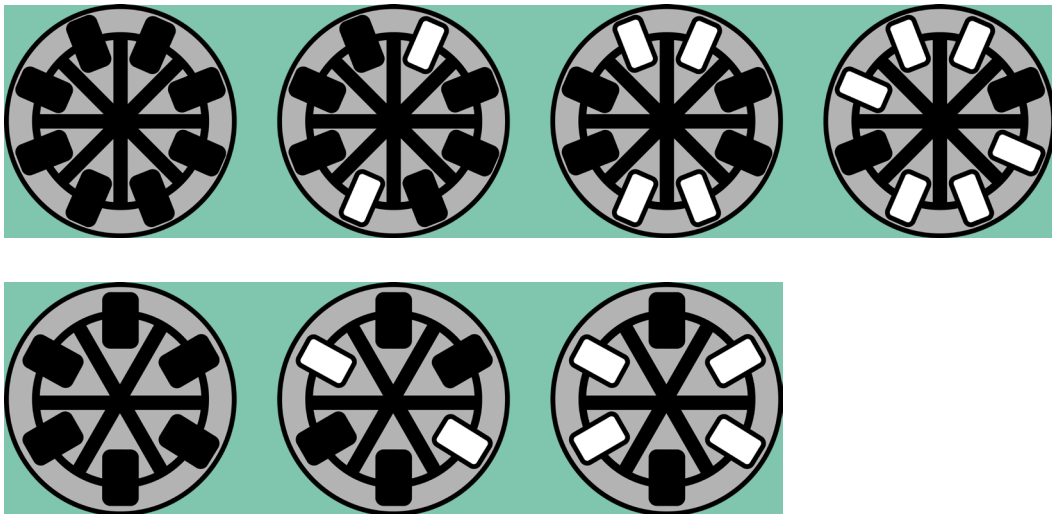

Figure III-10: Correct Loading

Incorrect Loading ✗

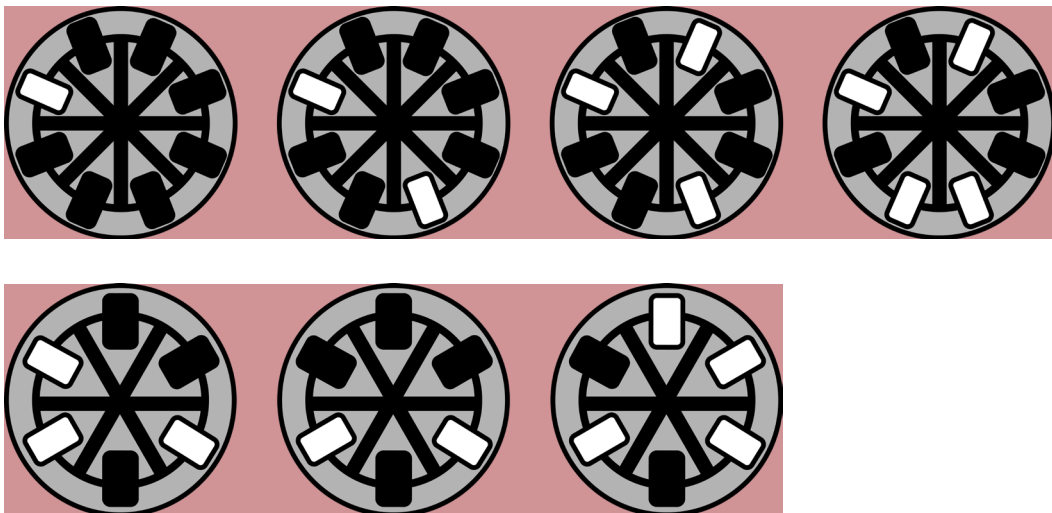

Figure III-11: Incorrect Loading

- Put the windshield lid into the holder at the inner side of the centrifuge door. The Thermo Scientific™ Auto-Lid™ function automatically opens and closes the windshield when the centrifuge door opens and closes.

The windshield lid has to be put into the holder at the inner side of the centrifuge door to correctly open and close the windshield.

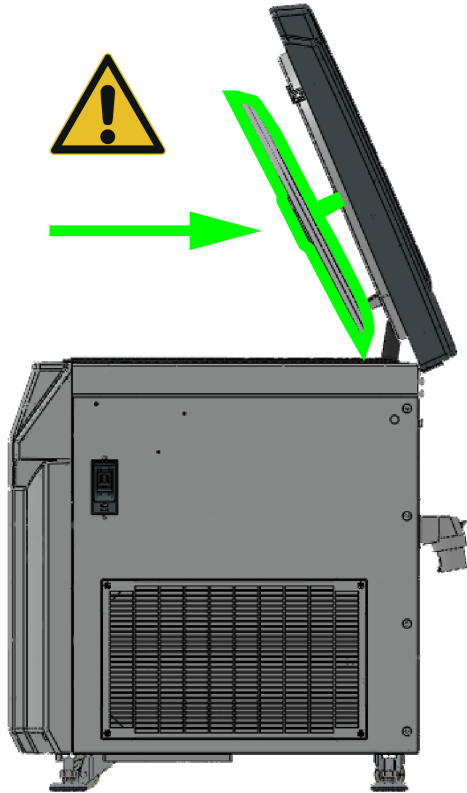

Figure III-12: Insert windshield lid into holder



CAUTION

Always put the windshield lid into the holder at the inner side of the centrifuge door. Make sure the rotor is locked properly. A missing windshield lid and an unlocked rotor can lead to severe damage of rotor and centrifuge.

4. Maximum Loading

Each rotor is designed to run with his maximum load at maximum speed. The safety system of the centrifuge requires that the rotor is not overloaded.

The rotors are designed to work with substance mixtures with a density of up to 1.2 g/ml. If the admissible maximum load is exceeded the following steps need to be taken:

- Reduce the fill level.
- Reduce the speed.

Use the table or the formula:

$$n_{adm} = n_{max} \sqrt{\frac{w_{max}}{w_{app}}}$$

n_{adm} = admissible maximum application speed

n_{max} = maximum rated speed

w_{max} = maximum rated load

w_{app} = applied load

Use of Tubes and Consumables

Care should be taken to ensure that the tubes and bottles used in the centrifuge are:

- rated to or above the selected RCF to be spun at,
- used at their minimum fill volume,
- not used above their design life (age or number of runs),
- undamaged.

Please refer to manufacturers data sheets for further information.

5. Close the Centrifuge Door



WARNING

Do not grab into the clearance between the centrifuge door and the housing. The centrifuge door shuts automatically. Put your hands always on top of the centrifuge door. Use the emergency release only for malfunctions and electrical failures ("[Mechanical Emergency Door Release](#)" on page V-1).

NOTICE

If the centrifuge door is open when the centrifuge is switched on, the centrifuge door needs to be closed manually. Only then, the centrifuge can be operated using the touchscreen.

Close the centrifuge door with the Auto-Door function by pressing on the **Close** button on the touchscreen. The centrifuge door will be automatically closed. Two locks close the centrifuge door fully. When closed, the touchscreen shows the **Start** button.

6. Entering Parameters

NOTICE

If the centrifuge door is open when the centrifuge is switched on, the centrifuge door needs to be closed manually. Only then, the centrifuge can be operated using the touchscreen.

6.1. Acceleration / Deceleration Profiles

There are 10 curves (1-10) for acceleration and 10 for deceleration (1-10). The acceleration / deceleration profile can be selected in the main screen.

Touch the number of the desired profile or move the slider by sliding your fingers over the numbers.

Select **Apply** to confirm this selection for the next run.

The profile with the lowest number has the shallowest incline marked with **min**; profile number 10 is the steepest incline which is marked with **max**.

6.2. Preselect Speed / RCF-Value

1. Press on the speed field on the main screen.
2. Press rpm or RCF. The selected function is highlighted in yellow.
3. Enter the desired value. The digits show in sequential order.
4. Confirm your entry by pressing **Confirm**.

NOTICE

If a speed or RCF-value out of the nominal range has been selected, a message will appear with the permissible values.

Explanation of RCF-Value

The relative centrifugal force (RCF) is given as a multiple of the force of gravity (g). It is a unit less numerical value which is used to compare the separation or sedimentation capacity of various centrifuges, since it is independent of the type of device. Only the centrifuging radius and the speed are used for calculation:

$$RCF = 11.18 \times \left(\frac{n}{1000}\right)^2 \times r$$

r = centrifuging radius in cm

n = rotational speed in rpm

The maximum RCF value is related to the maximum radius of the tube opening.

Remember that this value is reduced depending on the tubes and buckets used.

This can be accounted for in the calculation above if required.

6.3. Runtime Preselection

1. Press the time field on the main screen to open the runtime selection menu.
2. Press **Time, Hold** or $\int \omega^2 dt$, depending on the value you would like to change.
3. Enter the desired value using the numeric pad. The digits show in sequential order.
4. Confirm your entry by pressing **Confirm**.

Time	Hold	ACE
Duration of centrifugation; input as hh:mm. The set time is counted down when centrifugation is in progress. Initial value: Defined duration hh:mm:00	Unlimited duration of centrifugation. The time elapsed so far is displayed while centrifugation is in progress. Initial value: 00:00:00	Accumulated Centrifugal Effect enter in x.y * 10 ^z X: Whole digits (1 st input field) Y: Decimal numbers (2 nd input field) Z: Power (3 rd input field)

6.4. Preselect Temperature

You can preselect temperatures between -20 °C and 40 °C.

To set the temperature, proceed as follows:

1. Press the temperature field in order to open the temperature menu.
2. Enter the desired temperature. The digits show in sequential order.
3. Confirm your entry by pressing **Confirm**.

6.5. Pre-warm or Pre-cool the Centrifuge

To pre-temp the centrifuge, proceed as follows:

1. Use **Configuration** and **Runs** to select a stored program. The pre-temp function is connected to a program.
2. Press **Load** to select programmed parameters. In the main screen you can then set the required target temperature.

7. Programs

For detailed instructions and information refer to the according manual for the Thermo Scientific Centri-Touch User Interface.

The instructions stated here are just an extract of how to work with programs.

1. Press on the touchscreen.

If a program is already loaded, the program name will be shown on the button.

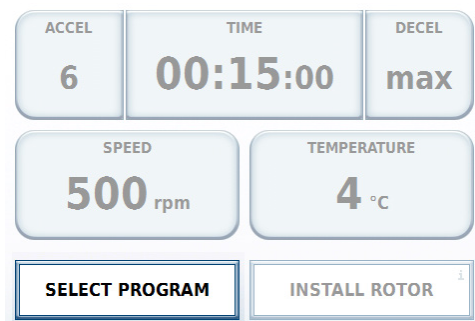

Figure III-13: Select program

2. Press **New**.
 - a. Check the parameter. Change the parameter if necessary.
To change a parameter, press the button of the parameter you want to change.
Press **Apply**.
 - b. Press **Enter Name**.
Enter a name for the program.
Press **Apply**.
 - c. Press **Select Rotor**.
Select a rotor.
Press **Apply**.
Select a bucket using the drop-down menu.
Press **Apply**.
3. Press **Apply** to save the program.
4. Press the new created program.
Press **Load**.
The program is now loaded and can be used.

8. Centrifugation



WARNING

Do not operate the centrifuge on its casters.



CAUTION

Make sure the rotor is locked properly into place before operating the centrifuge.

Make sure once a week that the rotor locking pin is locked properly. Use the rotor locking tool (20360104) clockwise to check, if the rotor locking pin is tightened to the firm stop.

8.1. Start

Press the **Start** key on the touchscreen. The centrifuge accelerates to the preset speed with the time display active. After 30 seconds the touchscreen switches to the lighthouse mode. Pressing anywhere on the touchscreen ends the lighthouse mode (“Lighthouse Mode” on page II-4).

You cannot open the centrifuge door as long as the centrifuge is running.

8.2. Stop

With preset Run Time

Usually the run time is preset and you only have to wait until the centrifuge stops automatically when the preset time limit expires.

As soon as the speed drops to zero, the message **Complete** will appear on the touchscreen. Press **Open Door** to open the centrifuge door and remove the samples.

You can also stop the centrifuging program manually at any time by pressing **Stop** . If the lighthouse mode is active, end it by pressing anywhere on the touchscreen (“Lighthouse Mode” on page II-4).

Continuous Operation

If you selected continuous operation, you will have to stop the centrifuge manually. Press **Stop**  on the touchscreen. The centrifuge will be decelerated at the designated rate. If the lighthouse mode is active, end it by pressing anywhere on the touchscreen (“Lighthouse Mode” on page II-4). The message **Complete** will appear on the touchscreen. Press **Open Door** to open the centrifuge door and remove the samples.

8.3. Using the Drain Box

You can use the drain box (75007730) to collect water from of the centrifugation chamber.

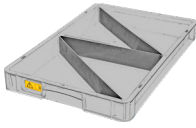

Figure III-14: Drain box (75007730)

1. Install the drain box.



Figure III-15: Installing the drain box (75007730)

2. Remove the plug from the bottom of the centrifugation chamber.

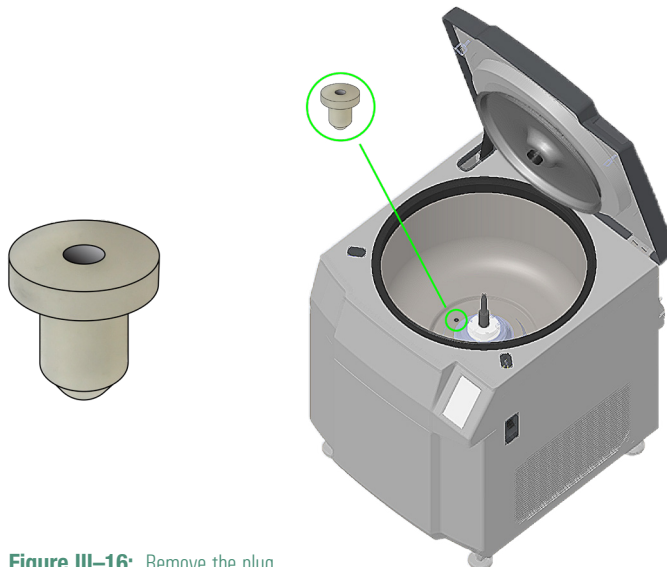

Figure III-16: Remove the plug

NOTICE Removing the plug and not installing the drain box will lead to spillage on the floor.

To remove the plug the centrifuge door must be open and the rotor including its windshield bowl has to be removed.

NOTICE Don't use any sharp tool to extract the plug. This might damage the centrifugation chamber.

3. You have to regularly check, if the drain box is filled and empty the drain box to avoid spilling on the floor.
4. Clean, disinfect and decontaminate the drain box as stated in "Maintenance and Care" on page IV-1.

9. Remove a Rotor



WARNING

Risk of cuts through fast rotating windshield lid.

Do not open the centrifuge door while the rotor assembly spins.

Only when the rotor assembly has stopped, use the mechanical emergency centrifuge door release.

NOTICE

For your protection when using an aerosol-tight rotor the bucket should only be removed with the lid closed.

NOTICE

Two people are necessary to remove the rotor because of its weight.

1. Open the centrifuge door. The centrifuge door lifts the windshield lid automatically.

The centrifuge door can only be opened when the centrifuge is switched on.

Press the **Open Door** button on the touchscreen. The centrifuge door will be automatically opened.



CAUTION

Do not use the mechanical emergency door release as regular procedure to open the centrifuge .

Use the mechanical emergency door release, only if a malfunction or power failure occurs and only when you have made sure that the rotor stopped spinning. ([“Mechanical Emergency Door Release” on page V-1](#))

2. Remove the windshield lid from the holder inside the centrifuge door.
3. Unload the buckets.
4. Remove the buckets.
5. Use the rotor locking tool (20360104) to disengage the rotor locking pin.

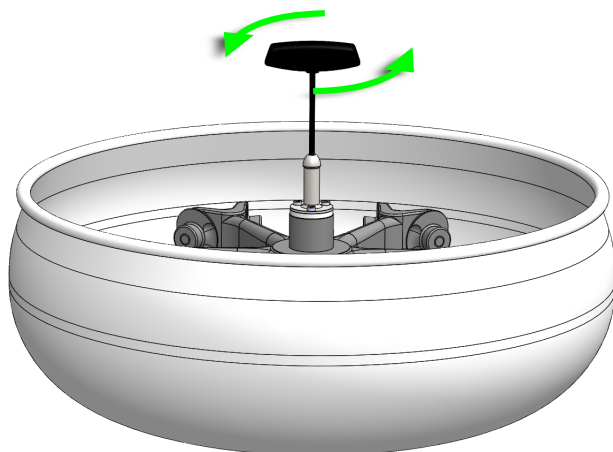

Figure III-17: Remove the rotor from the drive shaft.

6. Remove the rotor from the drive shaft.



CAUTION

The centrifuge drive can be damaged if the rotor body falls on it.

7. Hold the windshield knob with one hand and at the rim of the windshield bowl with the other.
Lift the windshield bowl straight from the drive shaft.
For some windshield bowls it may be easier to handle them with 2 persons.

10. Switch off the Centrifuge

Turn off the power supply switch located on right side of the centrifuge.

Maintenance and Care



1. Cleaning Intervals

For the sake of personal, environmental and material protection, you must clean and if necessary, disinfect the centrifuge and its components on a regular basis.

2. Basics



CAUTION

Not rated procedures or agents could deteriorate the materials of the centrifuge and lead to malfunction. Refrain from using any other cleaning or decontamination procedure, if you are not entirely sure that the intended procedure is safe for the equipment. Use only cleaning agents that will not damage the equipment. In doubt contact the manufacturer of the cleaning agent. If in doubt, contact Thermo Fisher Scientific.

- Use warm water with a neutral detergent that is suitable for use with the materials. If in doubt contact the manufacturer of the cleaning agent.
- Never use caustic cleaning agents such as soap suds, phosphoric acid, bleaching solutions or scrubbing powder.
- Remove rotor and clean centrifugation chamber with a small amount of cleaning agent on a clean cloth.
- Use a soft brush without metal bristles to remove stubborn residue.
Afterwards rinse with a small amount of distilled water and remove any remains with absorbent towels.
- Use only disinfectants with a pH of 6-8.

2. 1. Rotor and Components Inspection



CAUTION

Do not run any rotor or components with sign of damage.

Ensure that the rotor, buckets and components are within the service life and number of cycles.

It is recommend that you have rotors and components inspected yearly as part of your routine service to ensure safety.

After thoroughly cleaning the rotors, they must be inspected for damage, wear and corrosion.

The cycle limits of the rotors are stated in the technical data section of each rotor ("Rotors" on page B-1).

NOTICE Usage beyond these limits might lead to rotor failure, sample loss and damage to the centrifuge.

The cycle limits of the buckets are stated on the buckets themselves and stated in the technical data section of each rotor ("Rotors" on page B-1).

NOTICE Usage beyond these limits might lead to rotor failure, sample loss and damage to the centrifuge.

Metal Parts

Ensure that the protective coating is complete. It can be removed through wear and chemical attack and can lead to unseen corrossions. In case of corrosion, such as rust or white / metallic pitting, the rotor or components must be removed from service immediately. Particular attention should be paid to the bottom of buckets on swing out rotors and tube cavities on fixed angle rotors.

Plastic Parts

Check for signs of plastic crazing, fading, bruising or cracking. In case of damage, the inspected item must be removed from service immediately.

Cycles of Rotors and Buckets

The centrifuge counts cycles for a rotor type. The centrifuge does not count the cycles of the buckets. You have to count the cycles of the buckets using your own method. The centrifuge can not detect the change or replacement of rotors of the same type or buckets.

The service lifetime of a rotor and its buckets depends on the amount of physical load. Do not use rotors and buckets that exceed the maximum number of cycles.

The maximum number of cycles for rotors is given in the chapter "Rotors" on page B-1.

The maximum number of cycles for buckets is marked on the buckets themselves.

You can check the number of cycles for a rotor type on the user interface of the centrifuge. The rotor log saves the information of the used rotors and buckets. Press **Settings** (gears symbol), then **Runs** and then **Rotor Log** to see the information. Besides the values of the rotor an information about the number of cycles completed by this rotor type in this centrifuge is shown.

For detailed instructions and information refer to the separate manual for the Thermo Scientific Centri-Touch User Interface.

3. Cleaning



CAUTION

Before using any cleaning methods, users should check with the manufacturer of the cleaning agents that the proposed method will not damage the equipment.



CAUTION

Drive and door lock can be damaged by entering liquids. Do not allow liquids, especially organic solvents, to get on the drive shaft, the drive bearings or the centrifuge door locks.
Organic solvents break down the grease in the motor bearing. The drive shaft could lock up.

Clean as follows:

1. Clean rotor, buckets and components outside of the centrifugation chamber.
2. Separate rotor, buckets, lids, adapters and tubes to allow thorough cleaning.
3. Rinse rotor and all components with warm water and a neutral detergent that is suitable for use with the materials. If in doubt contact the manufacturer of the cleaning agent. Clean away the grease from the rotor trunnions (pivot point for swinging buckets).
4. Use a soft brush without metal bristles to remove stubborn residue.
5. Rinse rotor and all components with distilled water.
6. Place the rotors on a plastic grate with their cavities pointing down, to enable the cavities to fully drain and dry.
7. Dry all of the rotors and components after cleaning with a cloth or in a warm air cabinet at a maximum temperature of 50 °C. If drying boxes are used, the temperature must never exceed 50 °C. Higher temperatures could damage the material and shorten the lifetime of the parts.
8. Inspect the rotor and components for signs of damages. (["Rotor and Components Inspection" on page IV-2](#))
9. After cleaning, treat the entire surface of aluminum parts including the cavities with corrosion protection oil (70009824).
Treat the bolts of the swing out rotor with bolt grease (75003786).

Clean the bucket surfaces and rotor bolts as follows:

- a. Cut a cleaning pad (66309) into 12 mm (1/2 inch) wide strips.
- b. Saturate one of the pad strips with acetone or alcohol.
- c. Wrap the pad strip around a rotor bolt and move it back and forth in an oscillating motion. Move the strip around to clean the pin completely. Repeat this process for each rotor pin.
- d. Saturate another pad strip and thoroughly clean the bearing surfaces of each bucket.

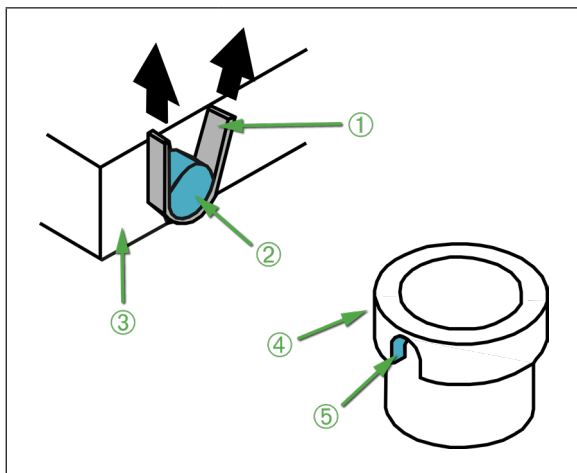

①	Cleaning pad strip
②	Rotor bolt
③	Rotor body
④	Bucket
⑤	Bearing Surface

Figure IV-1: Cleaning rotor bolts and bucket bearing surfaces

- e. Wipe the cleaned surfaces with a clean cloth.
- f. After cleaning, treat the entire surface of aluminum parts including the cavities with corrosion protection oil (70009824).
Treat the bolts of the swing out rotor with bolt grease (75003786).

3.1. Touchscreen

1. Pull out the power supply plug.
2. Clean the touchscreen using a dry microfiber cloth.
3. If necessary moisten the microfiber cloth and wipe the touchscreen again.

3.2. Filter Mat



CAUTION

Do not touch the edges of the housing with your hands when the grid is removed. Cutting damage can occur, if you touch the edges due to their sharpness.

The centrifuge has one filter mat to prevent dust from entering the centrifuge. To clean the centrifuge proceed as follows:

1. Remove the 4 screws of the grid ① on the right side of the centrifuge.
2. Remove the grid ② and the filter mat.
3. Use a vacuum cleaner on both sides of the filter mat.
4. Insert the filter mat again.
5. Reinstall the grid.

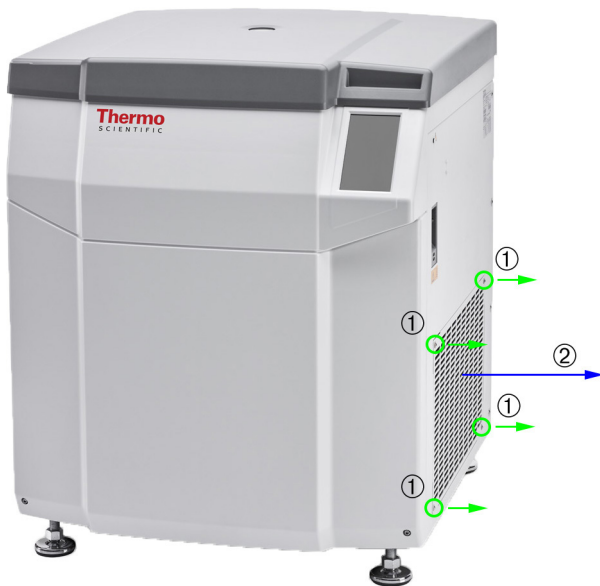

4. Disinfection



WARNING

Do not touch infected parts.

Hazardous infection is possible when touching the contaminated rotor and centrifuge parts. Infectious material can get into the centrifuge when a tube breaks or as a result of spills.

In case of contamination, make sure that no one is put at risk.

Disinfect the affected parts immediately.



CAUTION

Equipment can be damaged by inappropriate disinfection methods or agents.

Make sure that the disinfection agent or the method will not damage the equipment. In doubt contact the manufacturer of the disinfection agent.

Observe the safety precautions and handling instructions for the disinfection agents used.

After disinfection:

1. Rinse the centrifuge and all affected components with water.
2. Allow to fully drain and dry.
3. After disinfecting, treat the entire surface of aluminum parts including the cavities with corrosion protection oil (70009824).

Treat the bolts of the swing out rotor with bolt grease (75003786).

5. Decontamination



WARNING

Do not touch contaminated parts.

Exposure to radiation is possible when touching the contaminated rotor and centrifuge parts. Radioactive material can get into the centrifuge when a tube breaks or as a result of spills.

In case of contamination, make sure that no one is put at risk.

Decontaminate the affected parts immediately.



CAUTION

Equipment can be damaged by inappropriate decontamination methods or agents.

Make sure that the decontamination agent or the method will not damage the equipment. In doubt contact the manufacturer of the decontamination agent.

Observe the safety precautions and handling instructions for the decontamination agents used.

After decontamination:

1. Rinse the centrifuge and all affected components with water.
2. Allow to fully drain and dry.
3. After decontaminating, treat the entire surface of aluminum parts including the cavities with corrosion protection oil (70009824).

Treat the bolts of the swing out rotor with bolt grease (75003786).

6. Autoclaving



CAUTION

Never exceed the permitted temperature and duration when autoclaving.

NOTICE

No chemical additives are permitted in the steam.

Always disassemble all parts before autoclaving, e.g. lids need to be removed before autoclaving a bucket or rotor.

If not stated otherwise on the parts themselves, all parts can be autoclaved at 121 °C for 20 min:

- Metal Rotor Bodies
- Metal Buckets
- Adapter
- Volume Compensation Plates (75006681)
- Balancing Plates (75005759)
- Dummy Weights (75003866)
- Bucket lids
- Bottles

Make sure that the necessary sterility is achieved according to your requirements.

After autoclaving, treat the entire surface of aluminum parts including the cavities with corrosion protection oil (70009824).

Treat the bolts of the swing out rotor with bolt grease (75003786).

7. Maintenance

7.1. Preventive Maintenance

In order to keep this product able to perform the intended application in a reliable and safe state, ongoing preventive maintenance is necessary in accordance with the following recommended schedule:

- For rotors and buckets mind the information in ["Rotor and Components Inspection" on page IV-2](#).
- The anti-vibration mounts need to be replaced every 3 years.
- The rotor locking pin needs to be replaced every year.
- The centrifuge needs to be decommissioned after 15 years or 150 000 cycles, whichever comes first.

CAUTION Usage beyond these limits might affect the safety of the overall system.

7.2. Service

The anti vibration mounts (50151096) need to be replaced every three years by a Thermo Fisher Scientific authorized service technician or earlier if noticed. If the anti vibration mounts are not replaced within this period the performance of the centrifuge can decrease.

NOTICE In the worst case the centrifuge, the used components and the samples can be damaged.

Thermo Fisher Scientific recommends having the centrifuge and components serviced once a year by an authorized service technician. The service technician checks the following:

- electrical equipment;
- suitability of set-up site;
- centrifuge door lock and safety system;
- rotor;
- fixation of rotor and drive shaft of the centrifuge;
- protective casing;
- anti-vibration mounts.

Before service, centrifuge and rotors should be thoroughly cleaned and decontaminated to ensure full and safe inspection can be completed.

Thermo Fisher Scientific offers inspection and service contracts for this work. Any necessary repairs are performed for free during the warranty period and afterwards for a charge. That is only valid, if the centrifuge has only been maintained by an authorized Thermo Fisher Scientific service technician.

8. Shipping and Disposal



WARNING

When removing the centrifuge and components from use for disposal you have to clean and if necessary, disinfect or decontaminate the entire system. In doubt contact the Thermo Fisher Scientific customer service.

For the disposal of the centrifuge mind the regulations in your country. Contact the Thermo Fisher Scientific Customer Service for the disposal of the centrifuge. For contact information check the back page of this manual or visit

www.thermofisher.com/centrifuge

For the countries of the European Union the disposal is regulated by the European Union's Waste Electrical & Electronic Equipment (WEEE) Directive 2012/19/EU.

Mind the information on transport and shipping. ("Shipping" on page I-6 and "Transporting" on page I-2)

V

Troubleshooting

1. Mechanical Emergency Door Release



WARNING

Serious injuries can occur, if you touch a spinning rotor with your hands or tools.

A rotor can still be spinning after a power failure occurs.

Do not open the centrifuge before the rotor has stopped spinning. Do not touch a spinning rotor. Never use your hands or tools to stop a spinning rotor.

During a power failure, you will not be able to open the centrifuge door with the regular electric centrifuge door release. A mechanical override is provided to allow sample recovery in the case of an emergency. The mechanical override should be used only in emergencies and **after the rotor has come to a complete stop**.

Always wait until the rotor has come to a stop without braking. The brake does not work without power supply. The deceleration process lasts much longer than usual.

Proceed as follows:

1. **Wait until the rotor has stopped.** It can take longer than 40 minutes.

Use the sight glass in the centrifuge door to make sure that the rotor has stopped. The handle of the windshield lid has a marking, that shows a semicircle, if the rotor has stopped.

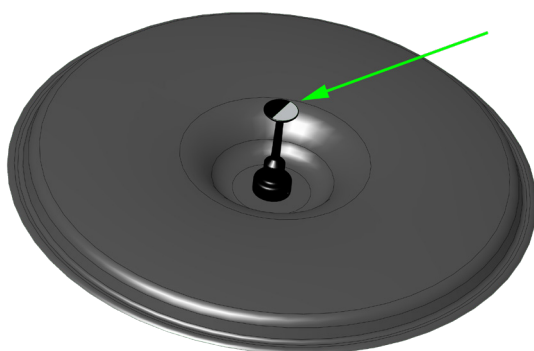

Figure V-1: Marking on windshield lid

2. Pull out the power supply plug.
3. On both sides of the housing are two white plastic plugs. Get these two white plastic plugs out of both sides of the housing. Pull the release cords on both sides to trigger the mechanical centrifuge door release. The centrifuge door needs to be lifted manually. You need some force to lift the centrifuge door manually.



Figure V-2: Position of the mechanical emergency door release

4. Put the release cords back into the centrifuge and put the white plastic plugs back into the centrifuge housing.
5. Reconnect the centrifuge to the power supply when the power failure has ended.

2. Ice Formation

Warm humid air in combination with a cold centrifugation chamber can lead to formation of ice.

To remove the ice out of the centrifugation chamber:

1. Open the centrifuge door.
2. Remove the rotor. See [“Remove a Rotor” on page III-14.](#)
3. Let the ice melt.

NOTICE Do not use any sharp tools, aggressive liquids or fire to fasten the melting process. If necessary use warm water to fasten the melting process.

4. Remove the water from the centrifugation chamber.

You can use the drain box (75007730) to remove the water from the centrifugation chamber. See [“Using the Drain Box” on page III-13.](#)

5. Clean the centrifuge chamber. See [“Maintenance and Care” on page IV-1.](#)

3. Troubleshooting by Guide



CAUTION

If problems occur other than those listed in this table, service technician must be contacted.

If an error occurs, follow the instructions on the touchscreen. Error messages have a red colored background.

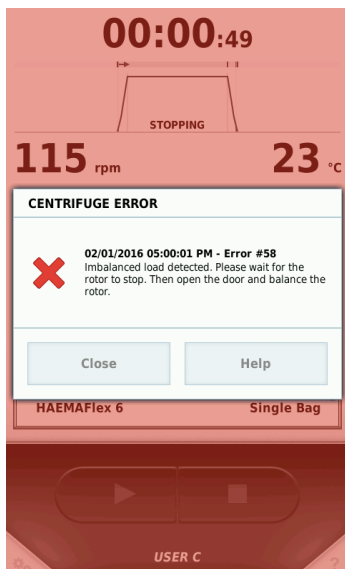

Figure V-3: Example for an error message

Error Message	Description	Troubleshooting
E-1 to E-97		Switch the centrifuge off and on again. Make sure that the correct windshield lid is inserted into the holder. Move the drive shaft slightly towards the front of the centrifuge. If the error message still shows, contact a service technician.
E-98	Centrifuge can not be operated. Centrifuge run can not be started or centrifuge is braking.	Imbalance detected. Check the loading of the rotor. Check the lubrication of the trunnion bolts of the rotor body. Switch the centrifuge off and on again. If the error message still shows, contact a service technician.
E-99		Switch the centrifuge off and on again. If the error message still shows, contact a service technician.

Table V-1: Error messages

4. Information for the Customer Service

If you need to contact a service technician, please provide the order no. and the serial no. of your centrifuge. This information can be found on the back near the inlet for the power supply cable.

To identify the software version, proceed as follows:

1. Switch on the centrifuge.
2. Open the configuration menu.
3. Select **Configuration**.
4. Select **Device**.

Now you can read all required data.



Technical Specifications

Environmental Conditions	Altitudes of up to 3000 m above sea level Max. relative humidity 80 % up to 31 °C; decreasing linearly to 50 % relative humidity at 40 °C
Environmental Conditions during Storage and Shipping	Temperature: -10 °C to 55 °C Humidity: 15 % to 85 %
Permissible Ambient Temperature during Operation	2 °C to 35 °C
Average Heat Dissipation	< 2 KW/h
Overvoltage Category	II
Pollution Degree	2
IP	20
Running Time	99 h 59 min 59 sec (1 second increment)
Maximum Speed n_{max} (Cryofuge 8 / Cryofuge 16) ¹	5000 rpm / 4700 rpm
Minimum Speed n_{min}	300 rpm
Maximum RCF Value at n_{max} (Cryofuge 8 / Cryofuge 16) ¹	7295 x g / 7187 x g
Noise Level at Maximum Speed ²	62 dB (A)
Maximum Kinetic Energy	225 KJ
Temperature Setting Range	-20 °C to 40 °C
Dimensions	
Height (open door / closed door)	1750 mm / 1015 mm (68.9 in / 39.4 in)
Width	816 mm (32.1 in)
Depth (with mains connection)	990 mm (38.9 in)
Weight ³	
200, 208, 220, 230, 240 V, 50/60 Hz	475 kg (1 047 lb)
380, 400, 415 V, 50 Hz	495 kg (1 090 lb)

¹ Cryofuge 16 includes the Cryofuge 16 Heavy Duty.

² 1 m in front of the instrument at 1.6 m height.

³ Without rotor.

Table A-1: Technical Data Thermo Scientific Cryofuge 8 / 16 and Cryofuge 16 Heavy Duty

1. Directives, Standards and Guidelines

Centrifuge	Region	Directive	Standard
Thermo Scientific Cryofuge 8 Thermo Scientific Cryofuge 16 Thermo Scientific Cryofuge 16 Heavy Duty	Europe Single Phase 220, 230 V, 50 / 60 Hz Poly Phase 380, 400, 415 V, 50 Hz	93/42/EEC Medical Devices 2011/65/EU RoHS Directive on the Restriction of the use of certain Hazardous Substances in electrical and electronic equipment Protective Goals of: 2006/42/EC Machinery 2014/35/EU Low Voltage 2014/30/EU Electromagnetic Compatibility (EMC)	EN 61010-1 IEC 61010-2-020 EN 61010-2-101 EN 61326-1 Class B EN 61326-2-6 EN 62304 EN 62366 EN ISO 14971 EN ISO 13485
	USA & Canada Single Phase 208, 230, 240 V, 60 Hz	FDA listed Product Code KSO Centrifuge, Blood-Bank For In Vitro Diagnostic Use Device Class 1	ANSI/UL 61010-1 IEC 61010-2-020 IEC 61010-2-101 IEC 61326-1 Class B IEC 61326-2-6 EN 62304 EN 62366 EN ISO 14971 EN ISO 13485
	Japan Single Phase 200 V, 50 / 60 Hz China Single Phase 220 V, 50 Hz Poly Phase 380 V, 50 Hz	CFDA listed	IEC 61010-1 3 IEC 61010-2-020 3 IEC 61010-2-101 3 IEC 61326-1 Class B IEC 61326-2-6 EN 62304 EN 62366 EN ISO 14971 EN ISO 13485

Table A-2: Directives, Standards and Guidelines Cryofuge 8 / 16 and Cryofuge 16 Heavy Duty

2. Refrigerants

Article No.	Centrifuge	Refrigerant	Quantity	Pressure	GWP	CO ₂ e
75007671	Thermo Scientific Cryofuge 8	R-449A	1.80 kg	34 bar	1397	2.51 t
75007672	Thermo Scientific Cryofuge 8	R-449A	1.80 kg	34 bar	1397	2.51 t
75007673	Thermo Scientific Cryofuge 16	R-449A	1.80 kg	34 bar	1397	2.51 t
75007674	Thermo Scientific Cryofuge 16	R-449A	1.80 kg	34 bar	1397	2.51 t
75007678	Thermo Scientific Cryofuge 16 Heavy Duty	R-449A	1.80 kg	34 bar	1397	2.51 t

Table A-3: Refrigerants used in the Cryofuge 8 / 16 and Cryofuge 16 Heavy Duty

Contains fluorinated greenhouse gases in a hermetically sealed system.

3. Mains Supply

The following data is to be taken into consideration, when selecting the mains connection socket.

Mains Voltage (V)	Frequency (Hz)	Rated Current (A)	Power Consumption (W)	Building Fuse (A) ¹	Equipment Fuse (A)
200	50	27.0	5100	30	30
208	50	24.0	5100	30	30
220	50	24.0	5100	30 ²	30
230	50	23.5	5100	30 ²	30
240	50	22.5	5100	30 ²	30
380	50	15.0	5100	16 ³	16
400	50	14.5	5100	16 ³	16
415	50	14.0	5100	16 ³	16
200	60	27.0	5350	30 ⁴	30
208	60	24.0	5350	30 ⁴	30
220	60	24.0	5350	30 ^{2,3}	30
230	60	23.5	5350	30 ^{2,3}	30
240	60	22.5	5350	30 ^{2,3}	30
380	60	15.0	5350	16 ³	16
400	60	14.5	5350	16 ³	16
415	60	14.0	5350	16 ³	16

¹ For the 200, 208, 220, 230, 240 V units the inrush current is 120 A for up to 1 second during the refrigeration start period. For the 380, 400, 415 V units it is 60 A. Circuit breakers, whether thermal or magnetic actuated, must have a delay type applicable for the start of motors.

² Use a 32 A Trip Char. C circuit breaker (D or K are also applicable).

³ For 380, 400, 415 V, 3-phase (unbalanced load, no neutral used) use a 16 A Trip Char. C circuit breaker (D or K are also applicable).

⁴For North America: use for example GES-9888 30 A.

Table A-4: Mains Supply

4. Components

Article No.	Description	Rotor Capacity	Max. Speed	Max. RCF
75007740	Sample Tracking Kit			
75007741	Networking Access Kit			
75007730	Drain Box (600 x 400 x 50 mm)			
75003861	HAEMAFlex 6 Swinging Bucket Rotor	6 x 500 ml		
75003881	HAEMAFlex 8 Swinging Bucket Rotor	8 x 550 ml		
75003834	Oval Single Blood Bag Bucket (set of 2)		5000 rpm	7127 x g
75003837	450 – 550 ml Quad or Quint Blood Bag Adapter (set of 2)	6 or 8 x 550 ml		
75003838	400 – 450 ml Double or Triple Blood Bag Adapter (set of 2)	6 or 8 x 450 ml		
75003839	250 ml Platelet-rich Plasma or Buffy Coat Bag Adapter (set of 2)	6 or 8 x 250 ml		
75003841	400 – 450 ml Single or Double Blood Bag Adapter (set of 2)	6 or 8 x 450 ml		
75003835	Single Blood Bag Bucket with Filter Pack (set of 2)		5000 rpm	7211 x g
75003842	450 – 550 Triple, Quad or Quint Blood Bag with Additive Solution Adapter (set of 2)	6 or 8 x 550 ml		
75003859	Filter Holder			
75003836	Single Blood Bag Round Bucket (set of 2)		5000 rpm	7295 x g
75003857	450 – 500 ml Triple or Quad Blood Bag Adapter (set of 2)	6 or 8 x 500 ml		
75003858	450 ml Single or Double Blood Bag Adapter (set of 2)	6 or 8 x 450 ml		
75003862	HAEMAFlex 12 Swinging Bucket Rotor	12 x 500 ml		
75003882	HAEMAFlex 16 Swinging Bucket Rotor	16 x 500 ml		
75003846	Double Blood Bag Bucket (set of 2)		4700 rpm	7187 x g
75003899	Double Quint Blood Bag Adapter for XXL size, HD (set of 2; 110 x 88 mm)	12 or 16 x 500 ml		
75003851	Double Quint Blood Bag Adapter for XXL size (set of 2; 110 x 88 mm)	12 or 16 x 500 ml		
75003852	Double Quint Blood Bag Adapter for XL size (set of 2; 110 x 76 mm)	12 or 16 x 500 ml		
75003853	Double Quint Blood Bag Adapter for M size (set of 2; 110 x 57 mm)	12 or 16 x 450 ml		
75003855	Hook Adapter for Cord Blood Separations, for use with M size Adapters	12 or 16 x 300 ml		1328 x g
75003868	Hook Adapter for Cord Blood Separations, for use with XXL size Adapters	12 or 16 x 300 ml		1328 x g
Other components for HAEMAFlex rotors				
75003843	Blood Bag Spacer (set of 12)			
75006681	Rubber Volume Compensation Plates (set of 12)			
75005759	Rubber Balancing Plates (set of 4)			

Article No.	Description	Rotor Capacity	Max. Speed	Max. RCF
75003866	Dummy Weights			
75003833	Linerstand for Single Blood Bag Adapters (set of 2)			
75003832	Linerstand for Double Blood Bag Adapters (set of 2)			

Table A-5: Components

B

Rotors

Items Supplied for Rotors

Article No.	Item	Quantity
	Rotor (incl. Windshield Bowl and Windshield Lid)	1
75003861	Thermo Scientific HAEMAFlex 6	
75003881	Thermo Scientific HAEMAFlex 8	
75003862	Thermo Scientific HAEMAFlex 12	
75003882	Thermo Scientific HAEMAFlex 16	
20360104	Rotor Locking Tool	1
75003786	Bolt Grease	1
70009824	Corrosion Protection Oil	1
66309	Cleaning Pad (6x)	1
75009709	Information Card	1

Table B-1: Items supplied for rotors

HAEMAFlex 6 Rotor

with Single Blood Bag Buckets (oval)



Technical Data

	Cryofuge 8	
Centrifuge Voltage	200, 208, 220, 230, 240 V	380, 400, 415 V
Rotor Capacity	6 x 1000 ml	6 x 1000 ml
Maximum Speed n_{max}	5000 rpm	5000 rpm
Maximum RCF-Value at n_{max}	7127 x g	7127 x g
K-Factor at n_{max}	8519	8519
Radius max. / min.	255 mm / 110 mm	255 mm / 110 mm
Angle	90°	90°
Maximum Speed at 4 °C	5000 rpm	5000 rpm
Sample Temperature at Max. Speed (Ambient temperature of 23 °C, run time 90 minutes)	50 Hz: 1 °C 60 Hz: -2 °C	50 Hz: 1 °C 60 Hz: -2 °C
Aerosol-tight	No	No
Permissible Temperature Range Autoclavable	121 °C	121 °C
Rotor Body Max. Cycle Number	50000	
Buckets Max. Cycle Number ¹ at		
7127 x g / 5000 rpm	18500	
5000 x g / 4188 rpm	35000	
4000 x g / 3746 rpm	53000	
2500 x g / 2961 rpm	124000	
Weight	19.8 kg	
Rotor Body (empty) with Windshield Bowl	18.3 kg	
Windshield Lid	1.5 kg	

¹ Cycle numbers stated are only valid, if the according speed (or rcf) is always set for centrifugation. If different speed (or rcf) settings are used, the smallest cycle number stated is valid.

Table B-2: HAEMAFlex 6 Rotor with Single Blood Bag Buckets (oval)

HAEMAFlex 6 Rotor

with Single Blood Bag Buckets (round)



Technical Data

	Cryofuge 8	
Centrifuge Voltage	200, 208, 220, 230, 240 V	380, 400, 415 V
Rotor Capacity	6 x 1000 ml	6 x 1000 ml
Maximum Speed n_{max}	5000 rpm	5000 rpm
Maximum RCF-Value at n_{max}	7295 x g	7295 x g
K-Factor at n_{max}	8216	8216
Radius max. / min.	261 mm / 116 mm	261 mm / 116 mm
Angle	90°	90°
Maximum Speed at 4 °C	5000 rpm	5000 rpm
Sample Temperature at Max. Speed (Ambient temperature of 23 °C, run time 90 minutes)	50 Hz: 1 °C 60 Hz: -2 °C	50 Hz: 1 °C 60 Hz: -2 °C
Aerosol-tight	No	No
Permissible Temperature Range Autoclavable	121 °C	121 °C
Rotor Body Max. Cycle Number	50000	
Buckets Max. Cycle Number ¹ at		
7295 x g / 5000 rpm	14000	
5000 x g / 4140 rpm	31000	
4000 x g / 3703 rpm	50000	
2500 x g / 2927 rpm	138000	
Weight	19.8 kg	
Rotor Body (empty) with Windshield Bowl	18.3 kg	
Windshield Lid	1.5 kg	

¹ Cycle numbers stated are only valid, if the according speed (or rcf) is always set for centrifugation. If different speed (or rcf) settings are used, the smallest cycle number stated is valid.

Table B-3: HAEMAFlex 6 Rotor with Single Blood Bag Buckets (round)

HAEMAFlex 6 Rotor

with Single Blood Bag Buckets with Filter Pack



Technical Data

	Cryofuge 8	
Centrifuge Voltage	200, 208, 220, 230, 240 V	380, 400, 415 V
Rotor Capacity	6 x 1000 ml	6 x 1000 ml
Maximum Speed n_{max}	5000 rpm	5000 rpm
Maximum RCF-Value at n_{max}	7211 x g	7211 x g
K-Factor at n_{max}	8365	8365
Radius max. / min.	258 mm / 113 mm	258 mm / 113 mm
Angle	90°	90°
Maximum Speed at 4 °C	5000 rpm	5000 rpm
Sample Temperature at Max. Speed (Ambient temperature of 23 °C, run time 90 minutes)	50 Hz: 1 °C 60 Hz: -2 °C	50 Hz: 1 °C 60 Hz: -2 °C
Aerosol-tight	No	No
Permissible Temperature Range Autoclavable	121 °C	121 °C
Rotor Body Max. Cycle Number	50000	
Buckets Max. Cycle Number ¹ at		
7211 x g / 5000 rpm	14000	
5000 x g / 4164 rpm	31000	
4000 x g / 3724 rpm	50000	
2500 x g / 2944 rpm	138000	
Weight	19.8 kg	
Rotor Body (empty) with Windshield Bowl	18.3 kg	
Windshield Lid	1.5 kg	

¹ Cycle numbers stated are only valid, if the according speed (or rcf) is always set for centrifugation. If different speed (or rcf) settings are used, the smallest cycle number stated is valid.

Table B-4: HAEMAFlex 6 Rotor with Single Blood Bag Buckets with Filter Pack

HAEMAFlex 8 Rotor

with Single Blood Bag Buckets (oval)



Technical Data

	Cryofuge 8	
Centrifuge Voltage	200, 208, 220, 230, 240 V	380, 400, 415 V
Rotor Capacity	8 x 1000 ml	8 x 1000 ml
Maximum Speed n_{max}	4600 rpm	4600 rpm
Maximum RCF-Value at n_{max}	7026 x g	7026 x g
K-Factor at n_{max}	8019	8019
Radius max. / min.	297 mm / 152 mm	297 mm / 152 mm
Angle	90°	90°
Maximum Speed at 4 °C	4600 rpm	4600 rpm
Sample Temperature at Max. Speed (Ambient temperature of 23 °C, run time 90 minutes)	50 Hz: 4 °C 60 Hz: 2 °C	50 Hz: 4 °C 60 Hz: 2 °C
Aerosol-tight	No	No
Permissible Temperature Range Autoclavable	121 °C	121 °C
Rotor Body Max. Cycle Number	50000	
Buckets Max. Cycle Number ¹ at		
7026 x g / 4600 rpm	14000	
5000 x g / 3881 rpm	31000	
4000 x g / 3471 rpm	50000	
2500 x g / 2744 rpm	138000	
Weight	28.8 kg	
Rotor Body (empty)	21.9 kg	
Windshield Lid	1.9 kg	
Windshield Bowl	5.0 kg	

¹ Cycle numbers stated are only valid, if the according speed (or rcf) is always set for centrifugation. If different speed (or rcf) settings are used, the smallest cycle number stated is valid.

Table B-5: HAEMAFlex 8 Rotor with Single Blood Bag Buckets (oval)

HAEMAFlex 8 Rotor

with Single Blood Bag Buckets (round)



Technical Data

	Cryofuge 8	
Centrifuge Voltage	200, 208, 220, 230, 240 V	380, 400, 415 V
Rotor Capacity	8 x 1000 ml	8 x 1000 ml
Maximum Speed n_{max}	4600 rpm	4600 rpm
Maximum RCF-Value at n_{max}	7144 x g	7144 x g
K-Factor at n_{max}	7831	7831
Radius max. / min.	302 mm / 157 mm	302 mm / 157 mm
Angle	90°	90°
Maximum Speed at 4 °C	4600 rpm	4600 rpm
Sample Temperature at Max. Speed (Ambient temperature of 23 °C, run time 90 minutes)	50 Hz: 4 °C 60 Hz: 2 °C	50 Hz: 4 °C 60 Hz: 2 °C
Aerosol-tight	No	No
Permissible Temperature Range Autoclavable	121 °C	121 °C
Rotor Body Max. Cycle Number	50000	
Buckets Max. Cycle Number ¹ at		
7144 x g / 4600 rpm	14500	
5000 x g / 3848 rpm	31000	
4000 x g / 3442 rpm	50000	
2500 x g / 2721 rpm	138000	
Weight	28.8 kg	
Rotor Body (empty)	21.9 kg	
Windshield Lid	1.9 kg	
Windshield Bowl	5.0 kg	

¹ Cycle numbers stated are only valid, if the according speed (or rcf) is always set for centrifugation. If different speed (or rcf) settings are used, the smallest cycle number stated is valid.

Table B-6: HAEMAFlex 8 Rotor with Single Blood Bag Buckets (round)

HAEMAFlex 8 Rotor

with Single Blood Bag Buckets with Filter Pack



Technical Data

	Cryofuge 8	
Centrifuge Voltage	200, 208, 220, 230, 240 V	380, 400, 415 V
Rotor Capacity	8 x 1000 ml	8 x 1000 ml
Maximum Speed n_{max}	4600 rpm	4600 rpm
Maximum RCF-Value at n_{max}	7073 x g	7073 x g
K-Factor at n_{max}	7942	7942
Radius max. / min.	299 mm / 154 mm	299 mm / 154 mm
Angle	90°	90°
Maximum Speed at 4 °C	4600 rpm	4600 rpm
Sample Temperature at Max. Speed (Ambient temperature of 23 °C, run time 90 minutes)	50 Hz: 4 °C 60 Hz: 2 °C	50 Hz: 4 °C 60 Hz: 2 °C
Aerosol-tight	No	No
Permissible Temperature Range Autoclavable	121 °C	121 °C
Rotor Body Max. Cycle Number	50000	
Buckets Max. Cycle Number ¹ at		
7073 x g / 4600 rpm	14000	
5000 x g / 3868 rpm	31000	
4000 x g / 3459 rpm	50000	
2500 x g / 2735 rpm	138000	
Weight	28.8 kg	
Rotor Body (empty)	21.9 kg	
Windshield Lid	1.9 kg	
Windshield Bowl	5.0 kg	

¹ Cycle numbers stated are only valid, if the according speed (or rcf) is always set for centrifugation. If different speed (or rcf) settings are used, the smallest cycle number stated is valid.

Table B-7: HAEMAFlex 8 Rotor with Single Blood Bag Buckets with Filter Pack

HAEMAFlex 12 Rotor

with Double Blood Bag Buckets



Technical Data

	Cryofuge 16 / Cryofuge 16 Heavy Duty	
Centrifuge Voltage	200, 208, 220, 230, 240 V	380, 400, 415 V
Rotor Capacity	12 x 1000 ml	12 x 1000 ml
Maximum Speed n_{max}	4700 rpm	4700 rpm
Maximum RCF-Value at n_{max}	7187 x g	7187 x g
K-Factor at n_{max}	7909	7909
Radius max. / min.	291 mm / 146 mm	291 mm / 146 mm
Angle	90°	90°
Maximum Speed at 4 °C	4600 rpm	4600 rpm
Sample Temperature at Max. Speed (Ambient temperature of 23 °C, run time 90 minutes)	50 Hz: 5 °C 60 Hz: 2 °C	50 Hz: 5 °C 60 Hz: 2 °C
Aerosol-tight	No	No
Permissible Temperature Range Autoclavable	121 °C	121 °C
Rotor Body Max. Cycle Number	50000	
Buckets Max. Cycle Number ¹ at		
7187 x g / 4700 rpm	14000	
5000 x g / 3921 rpm	31000	
4000 x g / 3507 rpm	50000	
2500 x g / 2772 rpm	137000	
Weight	25.6 kg	
Rotor Body (empty)	18.5 kg	
Windshield Lid	1.7 kg	
Windshield Bowl	5.4 kg	

¹ Cycle numbers stated are only valid, if the according speed (or rcf) is always set for centrifugation. If different speed (or rcf) settings are used, the smallest cycle number stated is valid.

Table B-8: HAEMAFlex 12 Rotor with Double Blood Bag Buckets

HAEMAFlex 16 Rotor

with Double Blood Bag Buckets



Technical Data

	Cryofuge 16 / Cryofuge 16 Heavy Duty	
Centrifuge Voltage	200, 208, 220, 230, 240 V	380, 400, 415 V
Rotor Capacity	16 x 1000 ml	16 x 1000 ml
Maximum Speed n_{max}	3900 rpm	3900 rpm
Maximum RCF-Value at n_{max}	5374 x g	5374 x g
K-Factor at n_{max}	10227	10227
Radius max. / min.	316 mm / 171 mm	316 mm / 171 mm
Angle	90°	90°
Maximum Speed at 4 °C	3900 rpm	3900 rpm
Sample Temperature at Max. Speed <small>(Ambient temperature of 23 °C, run time 90 minutes)</small>	50 Hz: 0 °C 60 Hz: -2 °C	50 Hz: 0 °C 60 Hz: -2 °C
Aerosol-tight	No	No
Permissible Temperature Range Autoclavable	121 °C	121 °C
Rotor Body Max. Cycle Number	50 000	
Buckets Max. Cycle Number ¹ at		
5374 x g / 3900 rpm	26500	
5000 x g / 3762 rpm	31000	
4000 x g / 3365 rpm	50000	
2500 x g / 2660 rpm	137000	
Weight	32.1 kg	
Rotor Body (empty)	24.7 kg	
Windshield Lid	1.9 kg	
Windshield Bowl	5.5 kg	

¹ Cycle numbers stated are only valid, if the according speed (or rcf) is always set for centrifugation. If different speed (or rcf) settings are used, the smallest cycle number stated is valid.

Table B-9: HAEMAFlex 12 Rotor with Double Blood Bag Buckets

Chemical Compatibility Chart

CHEMICAL	ALUMINUM	ALUMINUM COATING FOR ALUMINUM	BUNA N	CELLULOSE ACETATE BUTYRATE	POLYURETHANE ROTOR PAINT	COMPOSITE CARBON FIBER/EPOXY	DELPM™	ETHYLENE PROPYLENE	GLASS	NEOPRENE	NORL™	NYLON	PET, POLYCLEAR™, CLEAR CHIMP™	POLYALLUMER	POLYCARBONATE	POLYESTER, GLASS THERMOSET	POLYIMIDE	POLYETHYLENE	POLYPROPYLENE	POLYSULFONE	POLYVINYL CHLORIDE	RULON A™, TEFLON™	SILICONE RUBBER	STAINLESS STEEL	Titanium	Tygon™	Viton™
2-MERCAPTOETHANOL	S	S	U	/	S	M	S	/	S	U	S	S	U	S	S	/	S	S	S	S	U	S	S	S	S	S	S
ACETALDEHYDE	S	/	U	U	/	/	/	M	/	U	/	/	/	M	U	U	U	M	M	/	M	S	U	/	S	/	U
ACETONE	M	S	U	U	S	U	M	S	S	U	U	S	U	S	U	U	U	S	S	U	U	S	M	S	U	U	U
ACETONITRILE	S	S	U	/	S	M	S	/	S	S	U	S	U	M	U	U	/	S	M	U	U	S	S	S	U	U	U
ALCONOX™	U	U	S	/	S	S	S	/	S	S	S	S	S	S	M	S	S	S	S	S	S	S	S	S	S	U	U
ALLYL ALCOHOL	/	/	/	U	/	/	S	/	/	/	/	S	/	S	S	M	S	S	S	/	M	S	/	/	S	/	/
ALUMINUM CHLORIDE	U	U	S	S	S	S	U	S	S	S	S	M	S	S	S	S	/	S	S	S	S	M	U	U	S	S	
FORMIC ACID (100%)	/	S	M	U	/	/	U	/	/	/	/	U	/	S	M	U	U	S	S	/	U	S	/	U	S	/	U
AMMONIUM ACETATE	S	S	U	/	S	S	S	/	S	S	S	S	S	S	S	U	/	S	S	S	S	S	S	S	S	S	S
AMMONIUM CARBONATE	M	S	U	S	S	S	S	S	S	S	S	S	S	S	U	U	/	S	S	S	S	S	M	S	S	S	S
AMMONIUM HYDROXIDE (10%)	U	U	S	U	S	S	M	S	S	S	S	S	/	U	U	M	S	S	S	S	S	S	S	S	M	S	S
AMMONIUM HYDROXIDE (28%)	U	U	S	U	S	U	M	S	S	S	S	S	U	S	U	M	S	S	S	S	S	S	S	S	M	S	S
AMMONIUM HYDROXIDE (CONC.)	U	U	U	U	S	U	M	S	/	S	/	S	U	S	U	U	S	S	S	/	M	S	S	S	S	/	U
AMMONIUM PHOSPHATE	U	/	S	/	S	S	S	S	S	S	S	S	/	S	S	M	/	S	S	S	S	S	M	S	S	S	S
S	SATISFACTORY																										
M	MODERATE ATTACK, MAY BE SATISFACTORY FOR USE IN CENTRIFUGE DEPENDING ON LENGTH OF EXPOSURE, SPEED INVOLVED, ETC.; SUGGEST TESTING UNDER ACTUAL CONDITIONS OF USE																										
U	UNSATISFACTORY, NOT RECOMMENDED																										
/	PERFORMANCE UNKNOWN; SUGGEST TESTING, USING SAMPLE TO AVOID LOSS OF VALUABLE MATERIAL																										

Chemical Compatibility Chart

CHEMICAL	ALUMINUM	ANODIC COATING FOR ALUMINUM	BUNA N	CELLULOSE ACETATE BUTYRATE	POLYURETHANE ROTOR PAINT	COMPOSITE CARBON FIBER/EPOXY	DELPM™	ETHYLENE PROPYLENE	GLASS	NEOPRENE	NORL™	NYLON	PET, POLYCLEAR™, CLEAR CHIMP™	POLYALLUMER	POLYCARBONATE	POLYESTER, GLASS THERMOSET	POLYIMIDE	POLYETHYLENE	POLYPROPYLENE	POLYSULFONE	POLYVINYL CHLORIDE	RULON A™, TEFLON™	SILICONE RUBBER	STAINLESS STEEL	Titanium	Tygon™	Viton™
AMMONIUM SULFATE	U	M	S	/	S	S	U	S	S	S	S	S	S	S	S	S	/	S	S	S	S	S	S	U	S	S	U
AMYL ALCOHOL	S	/	M	U	/	/	S	S	/	M	/	S	/	M	S	S	S	S	M	/	/	/	U	/	S	/	M
ANILINE	S	S	U	U	S	U	S	M	S	U	U	U	U	U	U	U	/	S	M	U	U	S	S	S	U	S	S
SODIUM HYDROXIDE (<1%)	U	/	M	S	S	S	/	/	S	M	S	S	/	S	M	M	S	S	S	S	S	S	S	S	/	U	U
SODIUM HYDROXIDE (10%)	U	/	M	U	/	/	U	/	M	M	S	S	U	S	U	U	S	S	S	S	S	S	M	S	/	U	U
BARIUM SALTS	M	U	S	/	S	S	S	S	S	S	S	S	S	S	S	M	/	S	S	S	S	S	M	S	S	S	S
BENZENE	S	S	U	U	S	U	M	U	S	U	U	S	U	U	U	M	U	M	U	U	U	S	U	U	S	S	S
BENZYL ALCOHOL	S	/	U	U	/	/	M	M	/	M	/	S	U	U	U	U	U	U	U	/	M	S	U	/	S	/	S
BORIC ACID	U	S	S	M	S	S	U	S	S	S	S	S	S	S	S	S	U	S	S	S	S	S	S	S	S	S	S
CESIUM ACETATE	M	/	S	/	S	S	S	/	S	S	S	S	/	S	S	/	/	S	S	S	S	S	M	S	S	S	S
CESIUM BROMIDE	M	S	S	/	S	S	S	/	S	S	S	S	S	S	S	/	/	S	S	S	S	S	M	S	S	S	S
CESIUM CHLORIDE	M	S	S	U	S	S	S	/	S	S	S	S	S	S	S	/	/	S	S	S	S	S	M	S	S	S	S
CESIUM FORMATE	M	S	S	/	S	S	S	/	S	S	S	S	S	S	S	/	/	S	S	S	S	S	M	S	S	S	S
CESIUM IODIDE	M	S	S	/	S	S	S	/	S	S	S	S	S	S	S	/	/	S	S	S	S	S	M	S	S	S	S
S	SATISFACTORY																										
M	MODERATE ATTACK, MAY BE SATISFACTORY FOR USE IN CENTRIFUGE DEPENDING ON LENGTH OF EXPOSURE, SPEED INVOLVED, ETC.; SUGGEST TESTING UNDER ACTUAL CONDITIONS OF USE																										
U	UNSATISFACTORY, NOT RECOMMENDED																										
/	PERFORMANCE UNKNOWN; SUGGEST TESTING, USING SAMPLE TO AVOID LOSS OF VALUABLE MATERIAL																										

Chemical Compatibility Chart

CHEMICAL	ALUMINUM	ANODIC COATING FOR ALUMINUM	BUNA N	CELLULOSE ACETATE BUTYRATE	POLYURETHANE ROTOR PAINT	COMPOSITE CARBON FIBER/EPOXY	DELTA™	ETHYLENE PROPYLENE	GLASS	NEOPRENE	NORL™	NYLON	PET, POLYCLEAR™, CLEAR CHIMP™	POLYALLUMER	POLYCARBONATE	POLYESTER, GLASS THERMOSET	POLYIMIDE	POLYETHYLENE	POLYPROPYLENE	POLYSULFONE	POLYVINYL CHLORIDE	RULON A™, TEFLON™	SILICONE RUBBER	STAINLESS STEEL	Titanium	Tygon™	Viton™
CESIUM SULFATE	M	S	S	/	S	S	S	/	S	S	S	S	S	S	S	/	/	S	S	S	S	S	S	M	S	S	S
CHLOROFORM	U	U	U	U	S	S	M	U	S	U	U	M	U	M	U	U	U	M	M	U	U	S	U	U	M	S	S
CHROMIC ACID (10%)	U	/	U	U	U	U	U	/	/	/	S	U	U	S	M	U	M	S	S	U	M	S	/	U	/	S	S
CHROMIC ACID (50%)	U	/	U	U	/	/	U	/	S	U	U	U	U	U	U	/	/	U	U	/	U	S	/	S	S	U	S
CRESOL MIXTURE	S	S	U	/	/	/	S	S	S	U	U	U	U	U	U	M	S	M	U	M	M	S	S	S	S	U	S
CYCLOHEXANE	S	S	S	/	S	S	S	U	S	U	S	S	U	U	U	M	S	M	U	M	M	S	M	M	U	U	S
DEOXYCHOLAE	S	S	S	/	S	S	S	/	S	S	S	S	S	S	S	/	/	S	S	S	S	S	S	S	S	S	S
DISTILLED WATER	S	S	S	S	S	S	S	S	S	S	S	S	S	S	S	S	S	S	S	S	S	S	S	S	S	S	S
DEXTRAN	M	S	S	S	S	S	S	/	S	S	S	S	S	S	S	S	S	S	S	S	S	S	M	S	S	S	S
DIETHYL ETHER	S	S	U	U	S	S	S	U	S	U	U	S	U	U	U	U	U	U	U	U	U	S	S	S	M	U	U
DIETHYL KETONE	S	/	U	U	/	/	M	/	S	U	/	S	/	M	U	U	U	M	M	/	U	S	/	/	S	U	U
DIETHYLPYRO-CARBONATE	S	S	U	/	S	S	S	/	S	S	U	S	U	S	U	/	/	S	S	S	M	S	S	S	S	S	S
DIMETHYLSULFOXIDE	S	S	U	U	S	S	S	/	S	U	S	S	U	S	U	U	/	S	S	U	U	S	S	S	S	U	U
DIOXANE	M	S	U	U	S	S	M	M	S	U	U	S	U	M	U	U	/	M	M	M	U	S	S	S	S	U	U
S	SATISFACTORY																										
M	MODERATE ATTACK, MAY BE SATISFACTORY FOR USE IN CENTRIFUGE DEPENDING ON LENGTH OF EXPOSURE, SPEED INVOLVED, ETC.; SUGGEST TESTING UNDER ACTUAL CONDITIONS OF USE																										
U	UNSATISFACTORY, NOT RECOMMENDED																										
/	PERFORMANCE UNKNOWN; SUGGEST TESTING, USING SAMPLE TO AVOID LOSS OF VALUABLE MATERIAL																										

Chemical Compatibility Chart

CHEMICAL	ALUMINUM	ANODIC COATING FOR ALUMINUM	BUNA N	CELLULOSE ACETATE BUTYRATE	POLYURETHANE ROTOR PAINT	COMPOSITE CARBON FIBER/EPOXY	DELPM™	ETHYLENE PROPYLENE	GLASS	NEOPRENE	NORL™	NYLON	PET, POLYCLEAR™, CLEAR CHIMP™	POLYALLUMER	POLYCARBONATE	POLYESTER, GLASS THERMOSET	POLYIMIDE	POLYETHYLENE	POLYPROPYLENE	POLYSULFONE	POLYVINYL CHLORIDE	RULON A™, TEFLON™	SILICONE RUBBER	STAINLESS STEEL	Titanium	Tygon™	Viton™
FERRIC CHLORIDE	U	U	S	/	/	/	M	S	/	M	/	S	/	S	/	/	/	S	S	/	/	/	M	U	S	/	S
ACETIC ACID (GLACIAL)	S	S	U	U	S	S	U	M	S	U	S	U	U	U	U	U	M	S	U	M	S	S	U	S	/	U	U
ACETIC ACID (5%)	S	S	M	S	S	S	M	S	S	S	S	S	M	S	S	S	S	S	S	S	M	S	M	S	S	M	M
ACETIC ACID (60%)	S	S	U	U	S	S	U	/	S	M	S	U	U	M	U	S	M	S	M	S	M	S	U	S	M	U	U
ETHYL ACETATE	M	M	U	U	S	S	M	M	S	S	U	S	U	M	U	U	/	S	S	U	U	S	M	S	U	U	U
ETHYL ALCOHOL (50%)	S	S	S	S	S	S	M	S	S	S	S	S	U	S	U	S	S	S	S	S	S	S	M	S	M	U	U
ETHYL ALCOHOL (95%)	S	S	S	U	S	S	M	S	S	S	S	S	U	S	U	/	S	S	S	M	S	S	U	S	M	U	U
ETHYLENE DICHLORIDE	S	/	U	U	/	/	S	M	/	U	U	S	U	U	U	U	U	U	U	/	U	S	/	S	/	S	S
ETHYLENE GLYCOL	S	S	S	S	S	S	S	S	S	S	S	S	/	S	U	S	S	S	S	S	S	S	M	S	M	S	S
ETHYLENE OXIDE VAPOR	S	/	U	/	/	U	/	/	S	U	/	S	/	S	M	/	/	S	S	S	U	S	U	S	S	U	U
FICOLL-HYPAAQUE™	M	S	S	/	S	S	S	/	S	S	S	S	/	S	S	/	S	S	S	S	S	S	M	S	S	S	S
HYDROFLUORIC ACID (10%)	U	U	U	M	/	/	U	/	/	U	U	S	/	S	M	U	S	S	S	S	M	S	U	U	U	/	/
HYDROFLUORIC ACID (50%)	U	U	U	U	/	/	U	/	/	U	U	U	U	S	U	U	U	S	S	M	M	S	U	U	U	/	M
HYDROCHLORIC ACID (CONC.)	U	U	U	U	/	U	U	M	/	U	M	U	U	M	U	U	U	U	/	/	U	S	U	U	U	/	/
S	SATISFACTORY																										
M	MODERATE ATTACK, MAY BE SATISFACTORY FOR USE IN CENTRIFUGE DEPENDING ON LENGTH OF EXPOSURE, SPEED INVOLVED, ETC.; SUGGEST TESTING UNDER ACTUAL CONDITIONS OF USE																										
U	UNSATISFACTORY, NOT RECOMMENDED																										
/	PERFORMANCE UNKNOWN; SUGGEST TESTING, USING SAMPLE TO AVOID LOSS OF VALUABLE MATERIAL																										

Chemical Compatibility Chart

CHEMICAL	ALUMINUM	ANODIC COATING FOR ALUMINUM	BUNA N	CELLULOSE ACETATE BUTYRATE	POLYURETHANE ROTOR PAINT	COMPOSITE CARBON FIBER/EPOXY	DELFIN™	ETHYLENE PROPYLENE	GLASS	NEOPRENE	NORL™	NYLON	PET, POLYCLEAR™, CLEAR CHIMP™	POLYALLUMER	POLYCARBONATE	POYESTER, GLASS THERMOSET	POLYIMIDE	POLYETHYLENE	POLYPROPYLENE	POLYSULFONE	POLYVINYL CHLORIDE	RULON A™, TEFLON™	SILICONE RUBBER	STAINLESS STEEL	Titanium	Tygon™	Viton™
FORMALDEHYDE (40%)	M	M	M	S	S	S	S	M	S	S	S	S	M	S	S	S	U	S	S	M	S	S	S	M	S	M	U
GLUTARALDEHYDE	S	S	S	S	/	/	S	/	S	S	S	S	S	S	S	/	/	S	S	S	/	/	S	S	/	/	S
GLYCEROL	M	S	S	/	S	S	S	S	S	S	S	S	S	S	S	/	/	S	S	S	S	S	S	S	S	S	S
GUANIDINE HYDROCHLORIDE	U	U	S	/	S	S	S	/	S	S	S	S	S	S	S	/	/	S	S	S	S	S	U	S	S	S	S
HAEMO-SOL™	S	S	S	/	/	/	S	/	S	S	S	S	S	U	S	/	/	S	S	S	S	S	S	S	S	S	S
HEXANE	S	S	S	/	S	S	S	/	S	S	U	S	U	M	U	S	S	U	S	S	M	S	S	S	U	S	S
ISOBUTYL ALCOHOL	/	/	M	U	/	/	S	S	/	U	/	S	U	S	S	M	S	S	S	/	S	S	/	S	/	S	S
ISOPROPYL ALCOHOL	M	M	M	U	S	S	S	S	S	U	S	S	U	S	U	M	S	S	S	S	S	S	M	M	M	S	S
IODOACETIC ACID	S	S	M	/	S	S	S	/	S	M	S	S	M	S	S	/	M	S	S	S	S	S	S	S	M	M	S
POTASSIUM BROMIDE	U	S	S	/	S	S	S	/	S	S	S	S	S	S	S	S	S	S	S	/	S	S	M	S	S	S	S
POTASSIUM CARBONATE	M	U	S	S	S	S	S	/	S	S	S	S	S	U	U	S	S	S	S	S	S	S	S	S	S	S	S
POTASSIUM CHLORIDE	U	S	S	/	S	S	S	S	S	S	S	S	S	S	S	/	S	S	S	S	S	S	U	S	S	S	S
POTASSIUM HYDROXIDE (5%)	U	U	S	S	S	S	M	/	S	S	S	S	/	U	U	S	S	S	S	S	S	S	U	M	S	S	U
POTASSIUM HYDROXIDE (CONC.)	U	U	M	U	/	/	M	/	M	S	S	/	U	M	U	U	U	S	M	/	M	U	U	U	U	U	U
S	SATISFACTORY																										
M	MODERATE ATTACK, MAY BE SATISFACTORY FOR USE IN CENTRIFUGE DEPENDING ON LENGTH OF EXPOSURE, SPEED INVOLVED, ETC.; SUGGEST TESTING UNDER ACTUAL CONDITIONS OF USE																										
U	UNSATISFACTORY, NOT RECOMMENDED																										
/	PERFORMANCE UNKNOWN; SUGGEST TESTING, USING SAMPLE TO AVOID LOSS OF VALUABLE MATERIAL																										

Chemical Compatibility Chart

CHEMICAL	ALUMINUM	ANODIC COATING FOR ALUMINUM	BUNA N	CELLULOSE ACETATE BUTYRATE	POLYURETHANE ROTOR PAINT	COMPOSITE CARBON FIBER/EPOXY	DELN™	ETHYLENE PROPYLENE	GLASS	NEOPRENE	NORL™	NYLON	PET, POLYCLEAR™, CLEAR CHIMP™	POLYALLOMER	POLYCARBONATE	POVESTER, GLASS THERMOSET	POLYIMIDE	POLYETHYLENE	POLYPROPYLENE	POLYSULFONE	POLYVINYL CHLORIDE	RULON A™, TEFLON™	SILICONE RUBBER	STAINLESS STEEL	Titanium	Tygon™	Viton™	
POTASSIUM PERMANGANATE	S	S	S	/	S	S	S	/	S	S	S	U	S	S	S	M	/	S	M	S	U	S	S	M	S	S	U	S
CALCIUM CHLORIDE	M	U	S	S	S	S	S	S	S	S	S	S	S	S	M	S	/	S	S	S	S	S	S	M	S	S	S	S
CALCIUM HYPOCHLORITE	M	/	U	/	S	M	M	S	/	M	/	S	/	S	M	S	/	S	S	S	M	S	M	U	S	/	S	S
KEROSENE	S	S	S	/	S	S	S	U	S	M	U	S	U	M	M	S	/	M	M	M	S	S	U	S	S	U	S	S
SODIUM CHLORIDE (10%)	S	/	S	S	S	S	S	S	/	/	/	S	S	S	S	S	/	S	S	S	S	/	S	S	M	/	S	S
SODIUM CHLORIDE (SAT'D)	U	/	S	U	S	S	S	/	/	/	/	S	S	S	S	S	/	S	S	/	S	/	S	M	M	/	S	S
CARBON TETRACHLORIDE	U	U	M	S	S	U	M	U	S	U	U	S	U	M	U	S	S	M	M	S	M	M	M	U	S	S	S	S
AQUA REGIA	U	/	U	U	/	/	U	/	/	/	/	/	U	U	U	U	U	U	U	/	/	/	/	/	S	/	M	S
SOLUTION 555 (20%)	S	S	S	/	/	/	S	/	S	S	S	S	S	S	S	/	/	S	S	S	/	S	S	S	S	S	S	S
MAGNESIUM CHLORIDE	M	S	S	/	S	S	S	S	S	S	S	S	S	S	S	S	S	S	S	S	S	S	M	S	S	S	S	S
MERCAPTOACETIC ACID	U	S	U	/	S	M	S	/	S	M	S	U	U	U	U	/	S	U	U	S	M	S	U	S	S	S	S	S
METHYL ALCOHOL	S	S	S	U	S	S	M	S	S	S	S	S	U	S	U	M	S	S	S	S	S	S	S	M	S	M	U	U
METHYLENE CHLORIDE	U	U	U	U	M	S	S	U	S	U	U	S	U	U	U	U	U	M	U	U	U	S	S	M	U	S	S	U
METHYL ETHYL KETONE	S	S	U	U	S	S	M	S	S	U	U	S	U	S	U	U	U	S	S	U	U	S	S	S	S	U	S	U

S	SATISFACTORY
M	MODERATE ATTACK, MAY BE SATISFACTORY FOR USE IN CENTRIFUGE DEPENDING ON LENGTH OF EXPOSURE, SPEED INVOLVED, ETC.; SUGGEST TESTING UNDER ACTUAL CONDITIONS OF USE
U	UNSATISFACTORY, NOT RECOMMENDED
/	PERFORMANCE UNKNOWN; SUGGEST TESTING, USING SAMPLE TO AVOID LOSS OF VALUABLE MATERIAL

Chemical Compatibility Chart

CHEMICAL	ALUMINUM	ANODIC COATING FOR ALUMINUM	BUNA N	CELLULOSE ACETATE BUTYRATE	POLYURETHANE ROTOR PAINT	COMPOSITE CARBON FIBER/EPOXY	DELFIN™	ETHYLENE PROPYLENE	GLASS	NEOPRENE	NORL™	NYLON	PET, POLYCLEAR™, CLEAR CHIMP™	POLYALLUMER	POLYCARBONATE	POLYESTER, GLASS THERMOSET	POLYIMIDE	POLYETHYLENE	POLYPROPYLENE	POLYSULFONE	POLYVINYL CHLORIDE	RULON A™, TEFLON™	SILICONE RUBBER	STAINLESS STEEL	TITANIUM	TYGON™	VITON™
METRAMIDE™	M	S	S	/	S	S	S	/	S	S	S	S	/	S	S	/	S	S	S	S	S	S	M	S	S	S	S
LACTIC ACID (100%)	/	/	S	/	/	/	/	/	/	M	S	U	/	S	S	S	M	S	/	S	S	M	S	S	/	S	S
LACTIC ACID (20%)	/	/	S	S	/	/	/	/	/	M	S	M	/	S	S	S	S	S	S	S	S	M	S	S	/	S	S
N-BUTYL ALCOHOL	S	/	S	U	/	/	S	/	/	S	M	/	U	S	M	S	S	S	M	M	S	M	/	S	/	S	S
N-BUTYL PHTHALATE	S	S	U	/	S	S	S	/	S	U	U	S	U	U	U	M	/	U	S	S	S	M	M	S	U	S	S
N, N-DIMETHYLFORMAMIDE	S	S	S	U	S	M	S	/	S	S	U	S	U	U	U	/	/	S	U	U	S	M	S	S	S	S	U
SODIUM BORATE	M	S	S	S	S	S	S	S	S	S	S	U	S	S	S	/	/	S	S	S	S	S	M	S	S	S	S
SODIUM BROMIDE	U	S	S	/	S	S	S	/	S	S	S	S	S	S	S	/	/	S	S	S	S	S	M	S	S	S	S
SODIUM CARBONATE (2%)	M	U	S	S	S	S	S	S	S	S	S	S	S	U	S	S	S	S	S	S	S	S	S	S	S	S	S
SODIUM DODECYL SULFATE	S	S	S	/	S	S	S	/	S	S	S	S	S	S	S	/	S	S	S	S	S	S	S	S	S	S	S
SODIUM HYPOCHLORITE (5%)	U	U	M	S	S	M	U	S	S	M	S	S	S	M	S	S	S	M	S	S	S	U	U	S	M	S	S
SODIUM IODIDE	M	S	S	/	S	S	S	/	S	S	S	S	S	S	S	/	/	S	S	S	S	S	M	S	S	S	S
SODIUM NITRATE	S	S	S	/	S	S	S	S	S	S	S	S	S	S	S	/	/	S	S	S	S	U	S	S	S	S	S
SODIUM SULFATE	U	S	S	/	S	S	S	S	S	S	S	S	S	S	S	S	S	S	S	S	S	S	M	S	S	S	S
S	SATISFACTORY																										
M	MODERATE ATTACK, MAY BE SATISFACTORY FOR USE IN CENTRIFUGE DEPENDING ON LENGTH OF EXPOSURE, SPEED INVOLVED, ETC.; SUGGEST TESTING UNDER ACTUAL CONDITIONS OF USE																										
U	UNSATISFACTORY, NOT RECOMMENDED																										
/	PERFORMANCE UNKNOWN; SUGGEST TESTING, USING SAMPLE TO AVOID LOSS OF VALUABLE MATERIAL																										

Chemical Compatibility Chart

CHEMICAL	ALUMINUM	ANODIC COATING FOR ALUMINUM	BUNA N	CELLULOSE ACETATE BUTYRATE	POLYURETHANE ROTOR PAINT	COMPOSITE CARBON FIBER/EPOXY	DELTA™	ETHYLENE PROPYLENE	GLASS	NEOPRENE	NORL™	NYLON	PET, POLYCLEAR™, CLEAR CHIMP™	POLYALLUMER	POLYCARBONATE	POLYESTER, GLASS THERMOSET	POLYIMIDE	POLYETHYLENE	POLYPROPYLENE	POLYSULFONE	POLYVINYL CHLORIDE	RULON A™, TEFLON™	SILICONE RUBBER	STAINLESS STEEL	Titanium	Tygon™	Viton™
SODIUM SULFIDE	S	/	S	S	/	/	/	S	/	/	/	S	S	S	U	U	/	/	S	/	/	/	S	S	M	/	S
SODIUM SULFITE	S	S	S	/	S	S	S	S	M	S	S	S	S	S	S	M	/	S	S	S	S	S	S	S	S	S	S
NICKEL SALTS	U	S	S	S	S	S	/	S	S	S	/	/	S	S	S	S	/	S	S	S	S	S	M	S	S	S	S
OILS (PETROLEUM)	S	S	S	/	/	/	S	U	S	S	S	S	U	U	M	S	M	U	U	S	S	S	S	S	S	S	S
OILS (OTHER)	S	/	S	/	/	/	S	M	S	S	S	S	U	S	S	S	S	U	S	S	S	/	S	S	M	S	S
OLEIC ACID	S	/	U	S	S	S	U	U	S	U	S	S	M	S	S	S	S	S	S	S	S	S	U	S	M	M	M
OXALIC ACID	U	U	M	S	S	S	U	S	S	S	S	S	U	U	U	S	S	S	S	S	S	S	U	M	S	S	S
PERCHLORIC ACID (10%)	U	/	U	/	S	U	U	/	S	M	M	/	/	M	U	M	S	M	M	/	M	S	/	S	/	S	S
PERCHLORIC ACID (70%)	U	U	U	/	U	U	U	/	S	U	M	U	U	M	U	U	U	M	M	U	M	S	U	S	U	S	S
PHENOL (5%)	U	S	U	/	S	M	M	/	S	U	M	U	U	S	U	M	S	M	S	U	U	S	M	M	M	S	S
PHENOL (50%)	U	S	U	/	S	U	M	/	S	U	M	U	U	U	U	U	S	U	M	U	U	S	U	U	M	S	S
PHOSPHORIC ACID (10%)	U	U	M	S	S	S	U	S	S	S	S	U	/	S	S	S	S	S	S	S	S	S	M	U	U	S	S
PHOSPHORIC ACID (CONC.)	U	U	M	M	/	/	U	S	/	M	S	U	U	M	M	S	S	S	M	S	M	S	U	M	U	/	S
PHOSPHORIC ACID (SRAM, LHM)	M	S	S	S	/	/	S	/	S	S	S	S	S	S	S	S	S	S	S	S	S	S	S	S	S	S	S
S	SATISFACTORY																										
M	MODERATE ATTACK, MAY BE SATISFACTORY FOR USE IN CENTRIFUGE DEPENDING ON LENGTH OF EXPOSURE, SPEED INVOLVED, ETC.; SUGGEST TESTING UNDER ACTUAL CONDITIONS OF USE																										
U	UNSATISFACTORY, NOT RECOMMENDED																										
/	PERFORMANCE UNKNOWN; SUGGEST TESTING, USING SAMPLE TO AVOID LOSS OF VALUABLE MATERIAL																										

Chemical Compatibility Chart

CHEMICAL	ALUMINUM	ANODIC COATING FOR ALUMINUM	BUNA N	CELLULOSE ACETATE BUTYRATE	POLYURETHANE ROTOR PAINT	COMPOSITE CARBON FIBER/EPOXY	DELTA™	ETHYLENE PROPYLENE	GLASS	NEOPRENE	NORL™	NYLON	PET, POLYCLEAR™, CLEAR CHIMP™	POLYALLOMER	POLYCARBONATE	POLYESTER, GLASS THERMOSET	POLYIMIDE	POLYETHYLENE	POLYPROPYLENE	POLYSULFONE	POLYVINYL CHLORIDE	RULON A™, TEFLON™	SILICONE RUBBER	STAINLESS STEEL	Titanium	Tygon™	Viton™
PICRIC ACID	S	S	U	/	S	M	S	S	S	M	S	U	S	S	S	U	S	S	S	S	U	S	U	M	S	S	S
PYRIDINE (50%)	U	S	U	U	S	U	U	/	U	S	S	U	U	M	U	U	/	U	S	M	U	S	U	U	U	U	U
RUBIDIUM BROMIDE	M	S	S	/	S	S	S	/	S	S	S	S	S	S	S	/	/	S	S	S	S	S	M	S	S	S	S
RUBIDIUM CHLORIDE	M	S	S	/	S	S	S	/	S	S	S	S	S	S	S	/	/	S	S	S	S	S	M	S	S	S	S
SUCROSE	M	S	S	/	S	S	S	S	S	S	S	S	S	S	S	S	S	S	S	S	S	S	S	S	S	S	S
SUCROSE, ALKALINE	M	S	S	/	S	S	S	/	S	S	S	S	S	S	U	S	S	S	S	S	S	S	M	S	S	S	S
SULFOSAICYLIC ACID	U	U	S	S	S	S	S	/	S	S	S	U	S	S	S	/	S	S	S	/	S	S	U	S	S	S	S
NITRIC ACID (10%)	U	S	U	S	S	U	U	/	S	U	S	U	/	S	S	S	S	S	S	S	S	S	M	S	S	S	S
NITRIC ACID (50%)	U	S	U	M	S	U	U	/	S	U	S	U	U	M	U	U	M	M	M	S	S	S	U	S	M	S	S
NITRIC ACID (95%)	U	/	U	U	/	U	U	/	/	U	U	U	U	M	U	U	U	U	M	U	U	S	U	S	/	S	S
HYDROCHLORIC ACID (10%)	U	U	M	S	S	S	U	/	S	S	S	U	U	U	U	S	S	S	S	S	S	S	U	M	S	S	S
HYDROCHLORIC ACID (50%)	U	U	U	U	U	U	U	/	S	M	S	U	U	M	U	U	S	S	S	S	M	S	M	U	M	M	M
SULFURIC ACID (10%)	M	U	U	S	U	U	U	/	S	S	M	U	S	S	S	S	S	S	S	S	S	S	U	U	U	S	S
SULFURIC ACID (50%)	M	U	U	U	U	U	U	/	S	S	M	U	U	U	U	U	M	S	S	S	S	S	U	U	U	M	S
S	SATISFACTORY																										
M	MODERATE ATTACK, MAY BE SATISFACTORY FOR USE IN CENTRIFUGE DEPENDING ON LENGTH OF EXPOSURE, SPEED INVOLVED, ETC.; SUGGEST TESTING UNDER ACTUAL CONDITIONS OF USE																										
U	UNSATISFACTORY, NOT RECOMMENDED																										
/	PERFORMANCE UNKNOWN; SUGGEST TESTING, USING SAMPLE TO AVOID LOSS OF VALUABLE MATERIAL																										

Chemical Compatibility Chart

CHEMICAL	ALUMINUM	ANODIC COATING FOR ALUMINUM	BUNA N	CELLULOSE ACETATE BUTYRATE	POLYURETHANE ROTOR PAINT	COMPOSITE CARBON FIBER/EPOXY	DELN™	ETHYLENE PROPYLENE	GLASS	NEOPRENE	NORL™	NYLON	PET, POLYCLEAR™, CLEAR CHIMP™	POLYALLUMER	POLYCARBONATE	POYESTER, GLASS THERMOSET	POLYIMIDE	POLYETHYLENE	POLYPROPYLENE	POLYSULFONE	POLYVINYL CHLORIDE	RULON A™, TEFLON™	SILICONE RUBBER	STAINLESS STEEL	Titanium	Tygon™	Viton™
SULFURIC ACID (CONC.)	M	U	U	U	U	U	U	M	/	/	M	U	U	S	U	U	U	M	S	U	M	S	U	U	U	/	S
STEARIC ACID	S	/	S	/	/	/	S	M	S	S	S	S	/	S	S	S	S	S	S	S	S	S	M	S	S	S	S
TETRAHYDROFURAN	S	S	U	U	S	U	U	M	S	U	U	S	U	U	U	/	M	U	U	U	U	S	U	S	S	U	U
TOLUENE	S	S	U	U	S	S	M	U	S	U	U	S	U	U	U	S	U	M	U	U	U	S	U	U	U	U	M
TRICHLOROACETIC ACID	U	U	U	/	S	S	U	M	S	U	S	U	U	U	M	/	M	S	S	U	U	S	U	U	U	M	U
TRICHLOROETHANE	S	/	U	/	/	/	M	U	/	U	/	S	U	U	U	U	U	U	U	U	U	S	/	S	/	S	/
TRICHLOROETHYLENE	/	/	U	U	/	/	/	U	/	U	/	S	U	U	U	/	U	U	U	U	/	S	/	U	/	S	/
TRISODIUM PHOSPHATE	/	/	/	S	/	/	M	/	/	/	/	/	/	S	/	/	S	S	S	/	/	/	/	S	/	S	/
TRIS BUFFER (NEUTRAL PH)	U	S	S	S	S	S	S	/	S	S	S	S	S	S	S	S	S	S	S	S	S	S	S	S	S	S	S
TRITON X100™	S	S	S	/	S	S	S	/	S	S	S	S	S	S	S	S	S	S	S	S	S	S	S	S	S	S	S
UREA	S	/	U	S	S	S	S	/	/	/	/	S	S	S	M	S	S	S	S	/	S	S	M	S	/	S	/
HYDROGEN PEROXIDE (10%)	U	U	M	S	S	U	U	/	S	S	S	U	S	S	S	M	U	S	S	S	S	S	M	S	S	S	S
HYDROGEN PEROXIDE (3%)	S	M	S	S	S	/	S	/	S	S	S	S	S	S	S	S	M	S	S	S	S	S	S	S	S	S	S
XYLENE	S	S	U	S	S	S	M	U	S	U	U	U	U	U	U	M	U	M	U	U	U	S	U	M	S	U	S
S	SATISFACTORY																										
M	MODERATE ATTACK, MAY BE SATISFACTORY FOR USE IN CENTRIFUGE DEPENDING ON LENGTH OF EXPOSURE, SPEED INVOLVED, ETC.; SUGGEST TESTING UNDER ACTUAL CONDITIONS OF USE																										
U	UNSATISFACTORY, NOT RECOMMENDED																										
/	PERFORMANCE UNKNOWN; SUGGEST TESTING, USING SAMPLE TO AVOID LOSS OF VALUABLE MATERIAL																										

Chemical Compatibility Chart

CHEMICAL	ALUMINUM	ANODIC COATING FOR ALUMINUM	BUNA N	CELLULOSE ACETATE BUTYRATE	POLYURETHANE ROTOR PAINT	COMPOSITE CARBON FIBER/EPOXY	DELN™	ETHYLENE PROPYLENE	GLASS	NEOPRENE	NORL™	NYLON	PET, POLYCLEAR™, CLEAR CHIMP™	POLYALLUMER	POLYCARBONATE	POVESTER, GLASS THERMOSET	POLYTHERMIDE	POLYETHYLENE	POLYPROPYLENE	POLYSULFONE	POLYMIL CHLORIDE	RULON A™, TEFLON™	SILICONE RUBBER	STAINLESS STEEL	Titanium	Tygon™	Viton™
ZINC CHLORIDE	U	U	S	S	S	S	U	S	S	S	S	S	S	S	S	S	S	S	S	S	S	S	S	U	S	S	S
ZINC SULFATE	U	S	S	/	S	S	S	S	S	S	S	S	S	S	S	S	S	S	S	S	S	S	S	S	S	S	S
CITRIC ACID (10%)	M	S	S	M	S	S	M	S	S	S	S	S	S	S	S	S	M	S	S	S	S	S	S	S	S	S	S
S	SATISFACTORY																										
M	MODERATE ATTACK, MAY BE SATISFACTORY FOR USE IN CENTRIFUGE DEPENDING ON LENGTH OF EXPOSURE, SPEED INVOLVED, ETC.; SUGGEST TESTING UNDER ACTUAL CONDITIONS OF USE																										
U	UNSATISFACTORY, NOT RECOMMENDED																										
/	PERFORMANCE UNKNOWN; SUGGEST TESTING, USING SAMPLE TO AVOID LOSS OF VALUABLE MATERIAL																										

* Polyethyleneterephthalate

Table C-1: Chemical Compatibility

NOTICE

Chemical resistance data is included only as a guide to product use. Because no organized chemical compatibility data exists for materials under the stress of centrifugation, when in doubt we recommend pretesting sample lots.

Index

A

Acceleration / Deceleration Profiles [III-9](#)
 Aerosol-tight Rotors [III-9](#)
 Autoclaving [IV-7](#)

B

Basics [IV-1](#)
 Before Installation [III-2](#)

C

Centrifugation [III-12](#)
 Chemical Compatibility Chart [C-1](#)
 Cleaning [IV-3](#)
 Cleaning Intervals [IV-1](#)
 Close the Centrifuge Door [III-9](#)
 Components [A-4](#)
 Control and Configuration [II-3](#)

D

Decontamination [IV-6](#)
 Directives, Standards and Guidelines [A-2](#)
 Disinfection [IV-6](#)
 Drain Box [III-13](#)

E

Entering Parameters [III-9](#)
 Explanation of RCF-Value [III-10](#)

F

Filter Mat [IV-5](#)

H

HAEMAFlex 6 Rotor
 with Single Blood Bag Buckets (round) [B-3](#)
 HAEMAFlex 6 Rotor
 with Single Blood Bag Buckets with Filter Pack [B-4](#)
 HAEMAFlex 8 Rotor
 with Single Blood Bag Buckets (oval) [B-5](#)
 HAEMAFlex 8 Rotor
 with Single Blood Bag Buckets (round) [B-6](#)
 HAEMAFlex 8 Rotor
 with Single Blood Bag Buckets with Filter Pack [B-7](#)
 HAEMAFlex 12 Rotor
 with Double Blood Bag Buckets [B-8](#)
 HAEMAFlex 16 Rotor
 with Double Blood Bag Buckets [B-9](#)
 Hazardous Substances [ix](#)

I

Ice Formation [V-2](#)

Install a Rotor [III-2](#)
 Intended Use [vii](#)
 Intended User [vii](#)
 Items Supplied [vi](#)
 Items Supplied for Rotors [B-1](#)

L

Location [I-1](#)

M

Mains Connection [I-5](#)
 Mains Supply [A-3](#)
 Maintenance [x](#)
 Maintenance and Care [IV-1](#)
 Maximum Loading [III-8](#)
 Mechanical Emergency Door Release [V-1](#)
 Metal Parts [IV-2](#)

O

Open the Centrifuge Door [III-1](#)
 Operating [x](#)
 Operation [III-1](#)

P

Plastic Parts [IV-2](#)
 Precautions [viii](#)
 Preface [vi](#)
 Preparation [ix](#)
 Preselect Speed / RCF-Value [III-9](#)
 Preselect Temperature [III-10](#)
 Preventive Maintenance [IV-2](#)
 Pre-warm or Pre-cool the Centrifuge [III-10](#)
 Programs [III-11](#)

R

Refrigerants [A-3](#)
 Rotor and Accessories Inspection [IV-1](#)
 Rotor Installation [III-2](#)
 Rotors [B-1](#)
 Run Parameters [II-3](#)
 Runtime Preselection [III-10](#)

S

Setting Up [I-3](#)
 Set Up Conditions [viii](#)
 Shipping [I-6](#)
 Shipping and Disposal [IV-9](#)
 Status [II-2](#)
 Storage [I-5](#)
 6 x 1000 mL Swinging Bucket Rotor
 with Round Buckets [B-5](#)
 6 x 2000 mL Swinging Bucket Rotor
 with Oval Buckets [B-9](#)
 Switch on the Centrifuge [III-1](#)
 Symbols used in the Manual [xii](#)
 Symbols used on the Centrifuge [xi](#)

T

Technical Specifications [A-1](#)

Transport and Set Up [I-1](#)

Transporting [I-2](#)

Troubleshooting [V-1, V-3](#)

U

Unpacking [I-3](#)

Use of Tubes and Consumables [III-9](#)

Thermo Scientific Cryofuge 8 / 16
Thermo Scientific Cryofuge 16 Heavy Duty



Thermo Electron LED GmbH
Zweigniederlassung Osterode
Am Kalkberg, 37520 Osterode am Harz
Germany

thermofisher.com/centrifuge

© 2015-2021 Thermo Fisher Scientific Inc. All rights reserved.
All trademarks are the property of Thermo Fisher Scientific Inc. and its subsidiaries unless otherwise indicated.

Delrin, TEFLON, and Viton are registered trademarks of DuPont. Noryl is a registered trademark of SABIC. POLYCLEAR is a registered trademark of Hongye CO., Ltd. Hypaque is a registered trademark of Amersham Health As. RULON A and Tygon are registered trademarks of Saint-Gobain Performance Plastics. Alconox is a registered trademark of Alconox. Ficoll is a registered trademark of GE Healthcare. Haemo-Sol is a registered trademark of Haemo-Sol. Triton is a registered trademark of Union Carbide Corporation. Valox is a registered trademark of General Electric Co.

Specifications, terms and pricing are subject to change. Not all products are available in all countries. Please consult your local sales representative for details.

Shown pictures within the manual are examples and may differ considering the set parameters and language. Pictures of the user interface within the manual are showing the English version as example.

Australia +61 39757 4300

Austria +43 1 801 40 0

Belgium +32 9 272 54 82

China +800 810 5118, +400 650 5118

France +33 2 2803 2180

Germany national toll free
0800 1 536 376

Germany international +49 6184 90 6000

India toll free +1800 22 8374

India +91 22 6716 2200

Italy +39 02 95059 552

Japan +81 3 5826 1616

Korea +82 2 2023 0600

Netherlands +31 76 579 55 55

New Zealand +64 9 980 6700

Nordic/Baltic/CIS countries
+358 10 329 2200

Russia +7 812 703 42 15, +7 495 739 76 41

Singapore +82 2 3420 8700

Spain/Portugal +34 93 223 09 18

Switzerland +41 44 454 12 12

UK/Ireland +44 870 609 9203

USA/Canada +1 866 984 3766

Other Asian Countries +852 3107 7600

Countries not listed +49 6184 90 6000

en

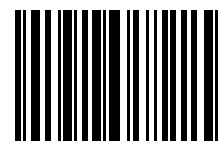

50149611